

Report

Aquaponic System II: The Monitoring

by
 Jan Rozewski,
 Rasmus von Bröckel,
 Francisco José Ruiz Ludeña,
 Katoo Van Tendeloo,
 Arick LV Davis,
 Stroe Viorel Dragos

Acknowledgement

The entire team expresses their gratitude to ISEP for giving us the opportunity of this project semester and providing us with the surrounding circumstances to make it a successful work. We want to thank the supervisory board as well as the teachers who supported us weekly and helped wherever they could. These weekly meetings and lectures gave us many impulses to improve and keep working during the whole working period. In addition Duarte, a local student from Computer Science, has been a great help at all times. Special thanks are owed to Maria Benedita Malheiro and Paulo Ferreira for their strong commitment to push us further at every step of the project as well as to Abel Duarte for the pleasant cooperation. During the period here, we became one big family and it was a great pleasure to be part of the EPS experience.

Glossary

Abbreviation	Description
α	Constant for use for natural convection
A_i	Inside area
A_o	Outside area
A_{Lm}	Logarithmic area of the film
AIDA	Awareness/Attention, Interest, Desire, Action
AIDAS	Awareness/Attention, Interest, Desire, Action, Satisfaction
ARM	Acorn RISC Machine
C	General-purpose programming language
C++	General-purpose programming language
c_p	Heat capacity
CPU	Central Processing Unit
CRM	Customer Relationship Management
D	Diameter
DC	Direct Current
e.g.	Exempli gratia

Abbreviation	Description
EPS	European Project Semester
EU	European Union
FMEA	Failure Modes and Effects Analysis
g	Gravitational acceleration
GHG	Greenhouse Gas
GPIO	General Purpose Input/Output
GPU	Graphics Processing Unit
GRAQ	Grupo de Reações e Análises Químicas
h	Film coefficient of heat transfer
h_i	Film coefficient of heat transfer inside
h_o	Film coefficient of heat transfer outside
HR	Human Resource
HRM	Human Resource Management
HTML	HyperText Markup Language
I	Impact
I_c	Cost Impact
I_s	Scope Impact
I_t	Time Impact
i.e.	Id est
ISEP	Instituto Superior de Engenharia do Porto
I/O	Input/Output
IEEE	Institute of Electrical and Electronics Engineers
k_{PEHD}	Thermal conductivity polyethylene high-density
LVD	Low Voltage Directive
m	Constant for use for natural convection
MCS	Management Control System
MD	Low Voltage EU Directive
MD5	Message Digest algorithm
microSD	Micro Secure Digital
MIS	Management Information System
MMC	MultiMediaCard
N_{Nu}	Nusselt number
N_{Pr}	Prandtl number
N_{Gr}	Grashof number
L	Length in meters
LED	Light-Emitting Diode
Linux	Computer operating system
P	Risk Probability
PBB	Polybrominated Biphenyls
PBDE	Polybrominated Diphenyl Ethers
PC	Personal Computer
PDU	Power Distribution Unit
PEHD	Polyethylene High-Density
pH	The negative log of the activity of the hydrogen ion in an aqueous solution
PHP	Hypertext Preprocessor

Abbreviation	Description
PMBOK	Project Management Body of Knowledge
POU	Point of Use
Python	High-level programming language
Q_{loss}	Total energy loss in time
QR	Quick Response
R&D	Research and Development
R&R	Roles and Responsibilities
RACI	Responsible, Accountable, Consulted, Informed
RISC	Reduced Instruction Set Computing
RoHS	Restriction of Hazardous Substances
RPI	Risk Priority Index
SD	Secure Digital
SDHC	Secure Digital High-Capacity
SDIO	Secure Digital Input Output
SDRAM	Synchronous Dynamic Random Access Memory
SME	Small and Medium Enterprise
SQL	Structured Query Language
STEP	Social, Technological, Economical and Political factors
STEEP	STEP, extended by the Environmental factor
SWOT	Strengths, Weaknesses, Opportunities and Threats for a product, company or project
TV	Television
U_o	Overall outside heat-transfer coefficient
UK	United Kingdom
USA	United States of America
USB	Universal Serial Bus
USD	US-Dollar
WAEE	Wisconsin Association for Environmental Education
WBS	Work Breakdown Structure
WEEE Directive	Waste Electrical and Electronic Equipment Directive
Wi-Fi	Wireless Fidelity
x	Thickness of the material
€	Euro
β	Volumetric coefficient of expansion of the fluid
μ	Viscosity
ΔT	Difference of temperature
ρ	Density







Units	
A	Ampere
cm	Centimetre
GB	Gigabyte
h	Hour
J	Joule
K	Kelvin

Units	
kg	Kilogram
m ²	Square meter
MB	Megabyte
Mbit	Megabit
MHz	Megahertz
mm	Millimetre
l	Litre
s	Second
V	Volt
W	Watt

1. Introduction

1.1 Presentation

We are a group of six students from six different countries (Spain, Romania, USA, Poland, Belgium & Germany) who came together at the end of February 2015 to work as a team during the spring semester. Our fields of studies vary from Graphic and Digital Design over Biomedical Engineering to Electrical Engineering.

					
Francisco José Ruiz Ludeña	Stroe Viorel Dragos	Arick LV Davis	Jan Rozewski	Katoo Van Tendeloo	Rasmus von Bröckel
Spain	Romania	USA	Poland	Belgium	Germany
Building and Civil Engineering	Industrial Design	Electrical Engineering	Biomedical Engineering	Graphic and Digital Design	International Marketing and Purchasing in Engineering

1.2 Motivation

Our motivation for fulfilling our objective during this semester comes from all the various skills and experience we can gather as a group. The goal is to achieve the best possible solution, to make it even easier for private households to possess and control their aquaponic system.

Katoo: “For me it’s interesting that it’s possible to grow your own food using fish. It will be a big improvement for humanity if we can all grow our own food. This project is about the monitoring of the aquaponic system from distance which makes the aquaponic system even more appealing. I don’t have the knowledge to build the electrical parts, but I’d like to contribute wherever I can.”

Viorel: “One important motivation was the opportunity to learn how an aquaponic system works and what possibilities exist to automate this system using accessible technology. The ability to grow fish and vegetables without spending important time to take care of them is, for sure, an important step towards a green future. This project requires vast knowledge to build a monitoring system, but a team with valuable members can finish it successfully.”

Rasmus: “Since I have a general interest in concerns of conscious nutrition, the project proposal of

monitoring an aquaponic system seemed ideal from the beginning on. Furthermore the different skills and abilities contributed by the various team members seem to perfectly match the requirements needed to actually finish the project with a successful, working product. Team work requires accepting compromises and communicating at all levels of the project phases. This can help each one of us to be prepared for future working experience and team based projects.”

Arick: “Though Aquaponic monitoring was not my first choice I knew it was one of few proposals that provided many opportunities to grow my understanding of electronics. The need for multiple sensors and communication via internet ensured that the project would not be simple. Having researched aquaponics in the past I understood the complexity of these types of systems. It was a good choice in project because it allowed for our entire team to be active in different ways.”

Francisco: “When we chose the project, I didn't like it. I live in a town where I have my olives, an orchard with a well where I sow tomatoes, lettuce and so on. Does this system produce truly foods as good as mine? I don't know but I realized that for those who live in the city and cannot get food grown by themselves, is a good choice. In addition, in the field of construction I think it might be interesting to build a building with this system. The tenants can get their own food and live in a slave city. So in the end I fell in love for aquaponic system.”

Jan: “Well, aquaponic system was far from my specialization and proficiencies. However, deeper insight allowed me to see the opportunity to learn a lot more about electronics, as well as, web coding I was never forced to explore while I really wanted to. What is more, it is not my first team project and I always enjoy working with people from whom I can learn and the EPS as a whole is the closest experience to regular scientific teamwork I can get during course of studies.”

1.3 Problem

An aquaponic system can greatly contribute to a household's food supply. But like all living creatures and plants, controlling and monitoring the system is indispensable and so far periods of absence can imply great risks, losses or make it even impossible to possess and run an aquaponic system. Furthermore the permanent changes in a globalised world make it more difficult for people to maintain a consistent and local way of living.

This is where our monitoring system comes into effect. It will enable users of aquaponic systems to monitor and operate their plants from anywhere via the internet. This is a great time saving installation as well as it makes the possession of aquaponics possible for those people with the interest but without the time or constant physical attendance.

1.4 Objectives

The goal is to construct a remote control and visualization via a mobile device of an aquaponic system with a 0.72 m² plant bed and a 700 l aquarium including a food dispenser, a camera as well as temperature and conductivity sensors. This technique then is supposed to increase the function, productivity and the ease of use for aquaponic system specifically.

Also one major objective is to reduce the client's maintenance hours by providing all around supervision. The consumer should be able to access essential information regarding his aquaponic system from wherever he physically is, as long as he has a connection to the internet. Moreover it should be feasible to regulate food dispensation, water temperature and the pump.

Concluding, the improvement of monitoring and controlling of every aquaponic is the central challenge we are facing. In order to provide an enhanced visualization it is mandatory to actually

make the handling as easy as possible and at the same time imply as complex functionalities as needed.

1.5 Requirements

The project requirements are:

1. Use of low cost hardware solutions
2. Use of open source and freeware.
3. Comply with the following EU Directives:
 1. Machine Directive ([2006/42/CE 2006-05-17](#));
 2. Electrical Safety: Low Level Voltage Directive ([2006/95/CE 2006-12-12](#));
 3. Restriction of Hazardous Substances (RoHS) in Electrical and Electronic Equipment Directive ([2002/95/EC 2003-01-27](#));
4. Mandatory adoption and use of the International System of Units ([The NIST International Guide for the use of the International System of Units](#))

Furthermore we had to think about the requirements which arise when looking from the perspective of the end consumers.

What do the final clients expect? How could we even outperform these expectations?

Since the goal is to develop a mobile device function to monitor and control one's aquaponic's system from wherever you are, as long as you have access to the internet, several questions came up how to fulfil this task.

The main focus clearly was to accomplish a universal, easy-to-handle and user-friendly technique. The target group is as diverse as it could be. This means that even people with little or almost no technical knowledge should be able to use our system in a satisfactory way.

The information the user receives must give him an appropriate overview about the conditions of his aquaponic system.

1.6 Functional Tests

Functional tests are supposed to include a live broadcasting camera from inside the fish tank, measurement temperature, and food dispensation. These functions should work over personal computers (PCs) and mobile devices. As long as these tests are successful we can be assured the rest system is working properly. If there are issues we can diagnose the problem through one of these test. Further details on this topic are discussed in sections 7.4 and 7.5.

1.7 Project Planning

In order to efficiently work on the project, we divided the next months in specific tasks and fields to work on. After defining these, we allocated them to different members of the team, depending on individual skills and abilities. Table 1 shows the tasks and their allocations.

Table 1: Task Allocation

Task	Responsible
Gantt Chart	Jan

Task	Responsible
Leaflet	Katoo
Research materials	Viorel, Jan & Arick
Marketing Plan	Rasmus & Katoo
Logbook	Rasmus
Eco-efficiency Measures for Sustainability	Rasmus, Arick, Katoo & Francisco
Ethical and Deontological Concerns	Jan
Pre-Development	Jan, Arick & Viorel
Investigation	All
Team Presentation	
Final Presentation	
Interim Report	
Final Report	
Development	
Functional testing	

1.8 Report Structure

The report is structured into eight major chapters, each containing several minor subjects. These are chosen as following:

1. Introduction: The team and the project are presented and introduced and the requirements are specified.
2. State of the Art: We present the various existing products and the progress of current technologies regarding our product.
3. Project Management: This chapter is all about the organisation and management of the ongoing project including tasks and timetables.
4. Marketing Plan: Deals with defining our specific target groups and markets and how we seek to differentiate from our competitors.
5. Eco-efficiency Measures for Sustainability: Points out the three pillars economical, environmental and social responsibility and develops a life-cycle analysis.
6. Ethical and Deontological Concerns: The focus lies on ethics in general and how these affect our project work.
7. Project Development: The ongoing development of our product and upcoming issues and progress.
8. Conclusion: We draw a final conclusion on the project, our achievements and future perspectives.

2. Aquaponic System

2.1 Introduction

State of the art can be defined as the level of development reached as far as a result of modern methods. Essentially, it means what was done in your field and what others are doing. The state of the art has influence on work, it will save time, save effort, save money and can avoid trouble with intellectual property. The research about the state of the art can be done after any type of books, where information is checked before publishing, it can be done after specific news science publications even before you find them in scientific databases, it can be done after patents where all the information is a research by strong teams or corporate research. The use of aquaponic systems is relatively recent, less than 20 years and at this time there were several companies and many homemade projects and we will mention them. In the upcoming chapter we will present competitive products with weak points and strong points.

2.2 Osmobot by Osmo Systems

The Osmobot device by Osmo System is focused on monitoring different types of systems [Osmobot, 2015]. The website of the product mentions the possibility to monitor a hydroponic, aquaponic, aquaculture and an aquarium system.

The system has built in a Wi-Fi adapter for internet communication and all the data is transferred and stored in a cloud server. You must pay 10 US-Dollar (USD) per month to have access to the monitoring data of your system over the internet. If any parameter is in critical stage the Osmobot will send you a mobile alert.

For a better understanding we will point out advantages and disadvantages. There is a summary in Table 2 about Osmobot.

Advantages and sensors of Osmobot are: pH sensor, dissolved oxygen monitor, water temperature, water level, air temperature, relative humidity, ammonia meter and nitrate sensor.

Disadvantages of Osmobot are: any add-on sensor or parameter will cost between 99 and 399 USD, mobile alert and communication with cloud server cost 10 USD monthly, without any control at all from distance.

Table 2: Osmobot overview

Product picture	Sensors	Price [USD]	Details about price
	pH	499	Standard price
	Dissolved oxygen in water	99-399	Additional price for specific sensors
	Water level	10/month	Online monitoring
	Water temperature		
	Air temperature		
	Humidity		

2.3 Smart Aquaponics Garden Controller by Kijani Grows

Kijani Grows produces and installs smart aquaponics gardens for homes, schools and corporate settings [Smart Aquaponics Garden Controller, 2015]. This product comes in different kits such as:

assembled kit for 690 USD, unassembled kit for 495 USD and the sensors kit for 205 USD. There is a summary in Table 3 about Kijani Grows' kits.

Their product comes with automated processes like pump cycles, water refilling, fish feeding and indoor light control to maintain an optimal grow environment. Real-time alerts (flow rates, irrigation, drainage, leaks, tank/reservoir levels, growbed levels) get sent to your email or mobile device via social networks (Twitter, Facebook) to let the user know when anything changes in the system. Meaning of alerts on social networks is about the ability of the system to post on a specific account at a specific period of time.

The advantages of Smart Aquaponics are: pump flow sensor, growbed water level sensor, fish tank level sensor, reservoir water level sensor, leak sensor, temperature sensor, light intensity, automatic fish feeder, post over a social network, email alerts and communication over Wi-Fi.

Disadvantages of Smart Aquaponics are: absence of information history, dependency on a social network account and a high price.

Table 3: Smart Aquaponics overview

Product picture	Sensors	Price [USD]	Details about price
	pump flow rate	690	Assembled kit
	Growbed water level	495	Unassembled kit
	Fish tank level	205	Just the sensors
	Reservoir water level		
	Growbed drainage		
	Leaks detector		
	Temperature		
	Light intensity		

2.4 Sensaphone400 and Sensaphone800 by Sensaphone

Sensaphone is a programmable, remote monitoring system that offers remote monitoring capability. It can be used for residences, small business, greenhouses, cold storage facilities or any remote facility. The system is designed to be mounted on a wall or on a desktop. Sensaphone uses telephone connections to call you and play prerecorded messages.

This system can set off a local alarm if a telephone line is cut and control a thermostat to adjust site temperature between two set points. Nonvolatile memory retains system settings in the event of

power loss.

The status of each monitored condition is readily obtained at the unit’s installation site or remotely by telephone. There is a summary in Table 4 about Sensaphone's products.

Sensaphone has two products: the first is [Sensaphone 400, 2015] for 749 USD (four sensor input) and the second is [Sensaphone 800, 2015] for 995 USD (eight sensor input).

First product, Sensaphone 400, comes with four sensors input such as: temperature sensor, air pressure sensor and humidity sensor.

The second product, Sensaphone 800, comes with the following sensors: temperature sensor, air pressure sensor, humidity sensor, water pressure sensor, backup power system (on/off) with included alert. Furthermore you still have three remaining inputs free for your choice.

Advantages of Sensaphone are: temperature sensor for water, temperature sensor for air, flow meter sensor, humidity sensor, alert in case of power failure, no internet connection for notifying the user, possibility to add or change sensor input and no monthly costs.

Disadvantages of Sensaphone are: no pH sensor, no database recording, no way to view your current status, absence of an automatic fish feeder, no water level sensor and no possibility to control remotely.

Table 4: Sensaphone overview

Product picture	Sensors	Price [USD]	Details about price		
	Air temperature	749	Sensaphone400		
	Water temperature	995	Sensaphone800		
	Flow meter				
	Humidity				

2.5 Open Aquarium by Cooking Hacks

Open Aquarium by Cooking Hacks allows the user to remotely control an aquarium and comes with a web application that allows to collect information, store in a database and visualize from a browser or from a smartphone device [Open Aquarium, 2015].





To achieve an aquaponic monitoring it requires the purchase of Open Aquarium Basic kit for 200 USD and Open Aquarium Aquaponics kit for 99 USD. Both kits deliver all the accessories (cables, screws, connectors, etc.) to build it yourself. There is a summary in Table 5 about Cooking Hacks' products. The basic kit comes with an Arduino board, an LED light, an automatic feeder, a temperature sensor and a water level sensor.

The second kit (Aquaponics kit) came with wireless module and additional sensors like: conductivity sensor, pH sensor, leakage detector and water heater.

Advantages of Cooking Hacks are: pH sensor, temperature sensor, water level sensor, conductivity sensor, water leak detector, automatic feeder for fish and a water heater.

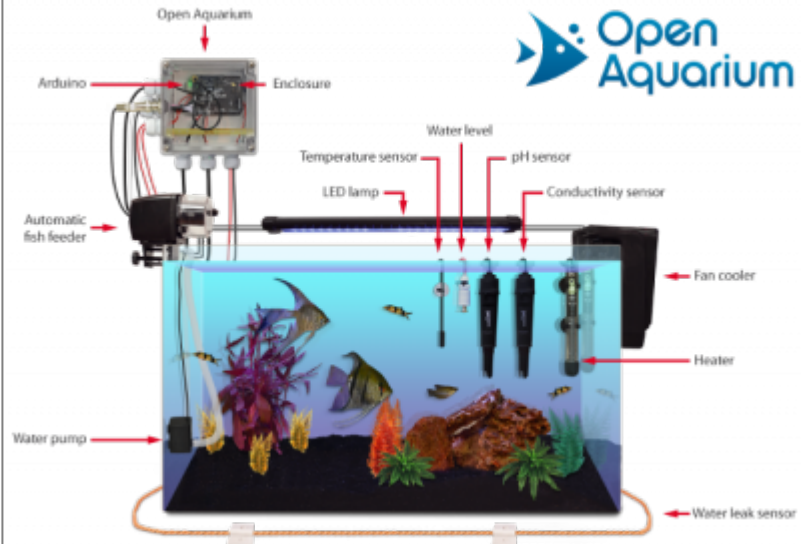
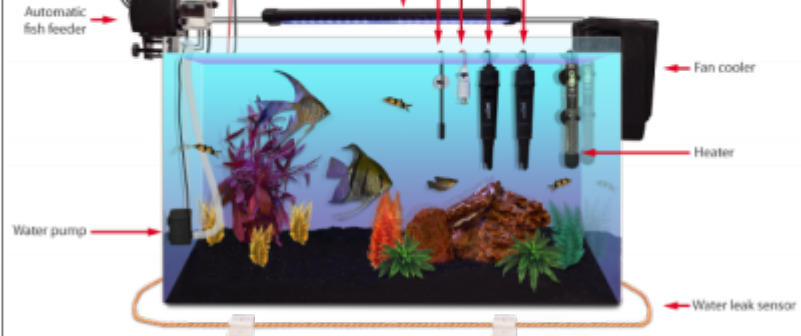
Disadvantages of Cooking Hacks are: no flow sensors and no remote control.

Table 5: Cooking Hacks overview

Product picture	Sensors	Price [USD]	Details about price
	Temperature	200	Open Aquarium Basic
	Water level		
	pH		
	Conductivity		
	Leaks detector		
			99 Open Aquarium Aquaponics

2.6 Aquaponic Admin by GRAQ/ISEP

We have proposed to enter on market with a product to compete at an affordable price without leaving behind quality. Our proposal product is to control and monitor an existing aquaponic system in order to obtain more time and easy control of your 'farm'.

Aquaponic Admin aims to monitor:

- Fish (video streaming)
- Pump function (flow sensor)
- Water temperature (temperature sensor)
- Water level (ultrasound depth sensor)
- Presence of food (infrared sensor)

And for controlling we aim to control: - Temperature (with a waterproof heater)

- Amount of food
- Light (on/off)
- Pump (on/off)

2.7 Conclusion

For conclusion section we summarize the whole products with our proposed final product in Table 6.

Table 6: Comparison table

	OSMOBOT	KIJANI GROWS	SENSAPHONE800	SENSAPHONE400	OPEN AQUARIUM	AQUAPONIC ADMIN
pH sensor	Yes	Yes	No	No	Yes	No
Temperature sensor	Yes	Yes	Yes	Yes	Yes	Yes
Flow sensor	No	Yes	Yes	Yes	No	Yes
Water level	No	Yes	No	No	Yes	Yes
Food dispenser	No	Yes	No	No	Yes	Yes
Video camera	No	No	No	No	No	Yes
Remote monitor	Yes	Yes	Yes	Yes	Yes	Yes
Remote control	Yes	No	Yes	Yes	No	Yes
Light	No	Yes	No	No	No	Yes
Email/SMS/WEB/Phone call notify	Yes	Yes	Yes	Yes	Yes	Yes
Price [USD]	499 +	205-690	995	749	299	< 280

We believe that we can develop a product that can be monitored remotely, controlled remotely, has local database, streaming video and is affordable for the average social class. In order to provide all these advantages, we will use open source software, free software and inexpensive hardware solutions.

In other words, our goal is to offer a final product with all important functionalities required at a low price.

3. Project Management

3.1 Scope

The aquaponic monitoring system uses the established requirements from the project description provided by the customer. With that in mind our focus is to develop a remote controlled aquaponic system with a food dispenser, video monitoring, temperature, and flow sensors. In addition the customer must have continuous access information about the system. To manage the project scope we maintained communication with the customer to ensure our product meets the needs without

overreaching or exceeding the budget. For the beginning, we gathered and figured out what different main and minor sections there were to work on during the entire project. The outcome is displayed in a WBS which can be seen in Figure 1.

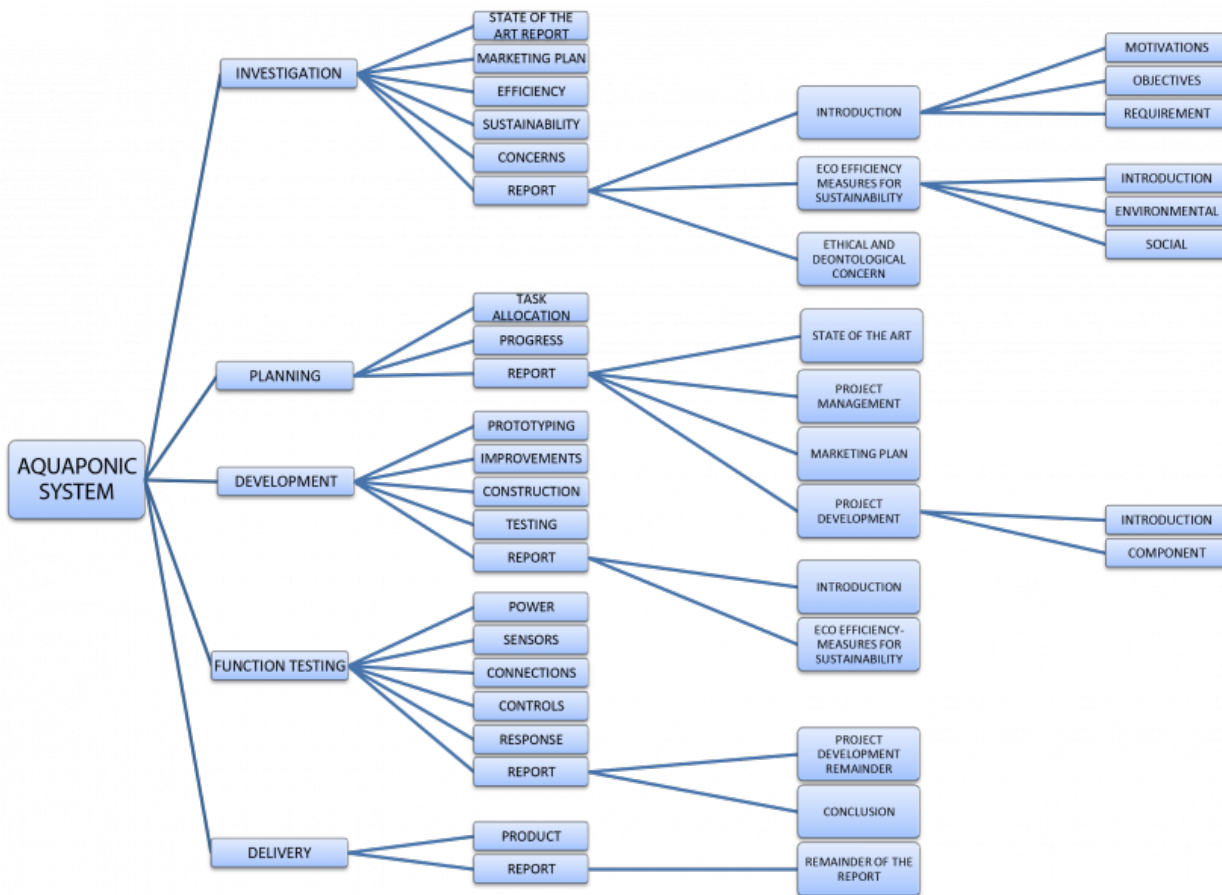

Figure 1: WBS

Deliverables: The files and works to be delivered and the deadlines were given by the EPS supervisory board.

Interim Report: This shows progress of the report at the middle point of the project and allows the team to receive feedback. Key portions of the report should be included.

Interim Presentation: This is an attempt to explain our progress at the middle point of the project and receive feedback in order to improve.

Leaflet: leaflet_eng.pdf This is a vibrant document to capture the attention of people who may be interested in our product and help them gain relevant information.

Final Report: This is a comprehensive document that explains in great detail everything in relation to our product and the progress over the entire project work with images, tables, charts and detailed text.

Final Presentation: This presentation is a final attempt to explain our progress as well as research and development of our product.

Paper: This document focuses on the technical and critical highlights of our research and project development.

Poster: This is a visual representation of the highlights and results of our project printed on an A3

page format.

Manual: The manual lists all the functions of our product. It furthermore explains how each module works; website database and hardware. The information in the manual will help the client understand how to use the product and perform future maintenance.

Video: This a 4-7 minute video that should summarize our entire EPS experience. Specifically our team, what we did for fun, product related progress during development and final product.

3.2 Time

Time management is an essential part of our project development. In order to work efficiently and to properly utilize all resources available, several tools described below were being used:

1. Task definition and allocation
 2. Required time estimation for tasks
 3. Gantt chart
 4. Deadline/milestone system
 5. Regular team meetings
 6. Online communication channels.
1. At the beginning of the project, the main goal was properly defined according to requirements delivered by the client and the EPS supervisory board. It was then split into specific phases corresponding with modules and report chapters. Further preparations consisted of defining specific tasks.
 2. With all the tasks defined, the time required for each of them to complete as well as placing them on the actual project timeline.
 3. The application of the Gantt chart allowed to create graphical representation of the work plan and to easily estimate at what periods the most work is required. What is more Gantt chart tool implemented in Microsoft Project allowed to create dependencies and co-dependencies between the tasks, which led to better understanding how the work should be scheduled.
 4. The deadline/milestone system is applied in order to ensure completion several phases of the project before defined date which, in result, allows a smooth workflow. **The deadline** is a period of time in which defined tasks must be completed. It is treated as a constraint and generally cannot be passed. **Milestones** serve as significant points in the project development such as the start, mid-term evaluation, beginning of assembly process and the end. What is important is that they don't influence the project duration. They are usually describing only critical elements omitting less relevant ones. The general idea behind the system is to set deadlines before milestones to ensure completion of all the tasks beforehand.
 5. Regular meetings are the tool allowing to better schedule and divide the work. By assembling the group together, we are able to present each progress if the tasks on which we are working and, if necessary assign additional resources to them.
Working together serves as well as a mean to improve the outcome of the work done in time. We achieve that by sharing our knowledge with teammates that are specializing in different fields and joining our expertise.
 6. Online communications channels have two essential functions.
 - First of all, they serve as the fastest way to schedule urgent meetings, share ideas and prepared parts of report. They are the most convenient and quickest means to do that.
 - Secondly, they are reliable and accessible all the time. That feature allows to share ideas without the need to organize the meeting every time.

Table 7: Timetable from Gantt chart

Start	End	Task	Who
06-03	18-06	Wiki	Rasmus von Bröckel, Francisco Jose Ruiz Ludeña, Arick Davis, Katoo Van Tendeloo, Jan Rożewski, Stroe Viorel
12-03	18-06	Progress	Rasmus von Bröckel, Francisco Jose Ruiz Ludeña, Arick Davis, Katoo Van Tendeloo, Jan Rożewski, Stroe Viorel
06-03	06-03	Resources	Arick Davis
06-03	11-03	State of the art report	Stroe Viorel
06-03	30-04	Marketing plan	Rasmus von Bröckel, Katoo Van Tendeloo
06-03	11-03	Efficiency	Jan Rożewski
06-03	11-03	Sustainability	Rasmus von Bröckel
06-03	11-03	Concerns	Stroe Viorel
06-03	06-03	Motivation	Rasmus von Bröckel
09-03	09-06	Objectives	Rasmus von Bröckel
10-03	10-03	Requirements	Rasmus von Bröckel
06-03	11-03	Task allocation	Arick Davis
19-03	03-04	Prototyping	Arick Davis, Katoo Van Tendeloo, Jan Rożewski, Stroe Viorel
20-04	15-05	Improvements	Arick Davis, Katoo Van Tendeloo, Stroe Viorel
18-05	22-05	Construction	Arick Davis, Katoo Van Tendeloo, Stroe Viorel
25-05	05-06	Testing	Arick Davis, Katoo Van Tendeloo, Jan Rożewski, Stroe Viorel
08-06	08-06	Power	Arick Davis, Katoo Van Tendeloo, Stroe Viorel
09-06	09-06	Sensors	Arick Davis, Katoo Van Tendeloo, Stroe Viorel
10-06	10-06	Connection	Arick Davis, Katoo Van Tendeloo, Jan Rożewski, Stroe Viorel
11-06	11-06	Controls	Rasmus von Bröckel, Francisco Jose Ruiz Ludeña, Arick Davis, Katoo Van Tendeloo, Jan Rożewski, Stroe Viorel
12-06	12-06	Response	Arick Davis, Katoo Van Tendeloo, Jan Rożewski, Stroe Viorel
08-06	18-06	Product	Rasmus von Bröckel, Francisco Jose Ruiz Ludeña, Arick Davis, Katoo Van Tendeloo, Jan Rożewski, Stroe Viorel

In Table 8 we constantly adjust current tasks and their status.

Table 8: Current Tasks

Word Formatting	2015/06/11 00:00	Rasmus	new
Project Management Communications	2015/04/23 00:00	Katoo	done
Ethics	2015/05/12 00:00	Francisco	done
Poster	2015/06/12 00:00	Katoo & Rasmus	new
Heater recalculation and correction	2015/05/18 00:00	Viorel	verified
detail improvements based on supervisor meetings	2015/05/25 00:00	All	done
Website Design	2015/06/26 00:00	Katoo	verified
chapter 3.5, 3.7, 3.9 & 3.10	2015/05/12 00:00	Rasmus	done
R&R Matrix	2015/04/27 00:00	Jan	done
Grammar corrections	2015/05/12 00:00	Francisco	started
chapter 3.6	2015/05/12 00:00	Katoo	done
chapter 7.3	2015/05/12 00:00	Viorel	accepted
update Glossary	2015/05/25 00:00	All	done

3.3 Cost

Our client is GRAQ (O Grupo de Reação e Análises Químicas - The Group of Reaction and Chemical Analysis) and we have a budget limit of 250 €.

Definition for cost management is the process of effectively planning and controlling the costs involved in a business [Liming Guan Maryanne Mowen Don Hansen, 2009].

Advantages of cost management are:

- Ability to predict a project's future expenses and costs.
- Maintenance of a central record of all predicted expenses.
- Ability to ensure that costs are approved before purchases are made.
- Ability to control a project's expenses.

We will split our costs in indirect cost and direct cost.

- **Indirect cost** represents the classroom where we work and our available laboratories and maintenance cost of these institutions. We can add here the cost of our teachers and supervisors. All these costs are covered by ISEP.

- **Direct cost** represents direct materials, consultants and project staff. All these costs are covered by our sponsor GRAQ.

More details about the direct cost will be in chapter 7 where we describe every specific product and his role.

Table 9 displays our human and materialistic resources and their allocation.

Table 9: Resource/Cost Management

Resource Name	Cost [€]	Type	Initials	Allocation [%]	Loan [€/hr] or Price [€/unit]	Overtime [€/h]	Cost/User	Accrue	Base
Arick	1500	Work	A	100	4	0	0	Prorated	Standard
Francisco	1500	Work	F	100	4	0	0	Prorated	Standard
Jan	1500	Work	J	100	4	0	0	Prorated	Standard
Katoo	1500	Work	K	100	4	0	0	Prorated	Standard
Rasmus	1500	Work	R	100	4	0	0	Prorated	Standard
Viorel	1500	Work	V	100	4	0	0	Prorated	Standard
Raspberry Pi	31.95	Material	RP		31.95			Prorated	
Arduino	22.90	Material	AR		22.90			Prorated	
USB cable Raspberry Pi	2.25	Material	UCRP		2.25			Prorated	
USB cable Arduino	2.85	Material	UCAR		2.85			Prorated	
Power supply Raspberry Pi	12.24	Material	PSRP		12.24			Prorated	
Jumper wires	12.00	Material	JW		12.00			Prorated	
Memory card	10.90	Material	MC		10.90			Prorated	
Webcam	11.90	Material	W		11.90			Prorated	
Wi-Fi dongle	9.80	Material	WF		9.80			Prorated	

Resource Name	Cost [€]	Type	Initials	Allocation [%]	Loan [€/hr] or Price [€/unit]	Overtime [€/h]	Cost/User	Accrue	Base
Arduino 4 channel relay module	12.90	Material	A4CRM		12.90			Prorated	
Water heater	38.61	Material	WH		38.61			Prorated	
Water pump	ISEP	Material	WP		0			Prorated	
LED light	7.40	Material	LL		7.40			Prorated	
Automatic fish feeder	15.89	Material	AFF		15.89			Prorated	
Step motor	ISEP	Material	SM		0			Prorated	
Temperature sensor	7.30	Material	TS		7.30			Prorated	
Water flow sensor	12.24	Material	WFS		12.24			Prorated	
Depth sensor	12.24	Material	DS		12.24			Prorated	
Infrared sensor	8.40	Material	IS		8.40			Prorated	

3.4 Quality

Quality management is a critical process that must be managed by multiple authorities. For all deliverables the work is reviewed by the team for information accuracy and ideas for improvement. Once a consensus is reached by the team we seek feedback from the appropriate advisor, if this option is available. Then it is submitted to the customer in its final state. Each deliverable has an individual list of checks it must pass before it is delivered to the customer.

For the actual product each module is tested independently before merged with another module. For example the website must be fully functional and the Raspberry Pi must reliably send and receive data, before the Pi is allowed to automatically send data to the data server.

3.5 People

As for people within a project, there are different groups taken into account. By the term people we mainly think of stakeholders, team members and project manager. In the existent case the project manager also takes an essential role as a team member.

It is not only the way and methods of communication that form a foundation of highly functional team work and by this a successful progress within the project progress. The behaviour of the people involved must also be considered. There are many manners of either positive or negative human nature that can influence a project's development. These can either be the unwillingness to fulfil certain assigned tasks because of the fact that a team member *e.g.* feels subchallenged or overcharged or the excitement of another team member that comes from the intention to make the project a success.

In this chapter we focus on the task allocations of each member as well as on how to arrange the constraint of Human Resources (HRs). Furthermore we evaluate roles and responsibilities of the entirety of people involved in the ongoing project.

“Human resource management (HRM) includes five broad activities that together constitute the HRM system: staffing, retention, development, adjustment, and managing change. Its objectives are to optimize the performance and productivity of all workers in an organization, and to help line managers manage those workers more effectively.” [Wayne F. Cascio, 2015].

“Human resource management can be viewed as core processes of the project-oriented company, affecting the way the organization acquires and uses human resources, and how employees experience the employment relationship” [J. Rodney Turner Anne Keegan Martina Huemann, 2007].

Identifying every person taking part in the project development is crucial for maintaining efficient communication, task distribution and work schedule. In order to create work division in a multi-field group a tool known as roles and responsibilities matrix (R&R) would be applied. The matrix describes the roles and responsibilities of project participants related to specific tasks. For the project the RACI method was applied. The acronym is derived from four roles concerning the specific tasks:

- Responsible;
- Accountable;
- Consulted;
- Informed;

Table 10: R&R matrix

Task/Resource	Arick Davis	Stroe Viorel Dragos	Rasmus von Bröckel	Francisco José Ruiz Ludeña	Katoo Van Tendeloo	Jan Rożewski	Abel José Duarte	Paulo Ferreira	Supervisors	Luis Castanheira	Ana Barata	Alberto Pereira	Francisco Jose Vieira	Andreia Taveira da Gama	Benedita Malheiro
Aquaponic system controls	R	R	R	R	R	R	C/I	C/I	C/I	C/I	C/I	C/I	C/I	C/I	C/I
Interim presentation	R	R	R	R	R	R	C	C	C	C	C	C	C	C	C
Paper	R	R				A	I	C	C		C				I
Video		R	R		A		I	I	I		C			C	I
Poster		R	R		A		I	I	C		C			C	I
User manual	A	R					C	C	C		C				C/I
Final presentation	R	R	R	A	R	R	C	C	C	C	C	C	C	C	C
Product	A	R	R	R	R	R	C	C	C	C	C	C	C	C	C
Web application	A				R		I	C	C						C
Website layout					A		I	C	C						I
Arduino code						A	I	C	C						C
Raspberry Pi Code	A						I	C	C						C
Function testing	C	R				A	C	C	C						C/I
Report	R	R	A	R	R	R		C	C	C	C	C	C	C	C
Introduction	R	R	A	R	R	R		C	C	C	C	C	C	C	C
State of the Art		A					I	C	C						C
Project management		R	A		R	R	I	I	C			C			I
WBS						A	I	I	C			C			I
Gantt chart						A	I	I	C			C			I
Marketing plan			A				I	I	C					C	I
Eco-efficiency measures for sustainability				A	R		I	I	C	C					I
Ethical and deontological concerns				A	R	R	I	I	C			C			I
Project development	A	R				R	C	C	C						C
Conclusions	R	R	A	R	R	R	I	C	C						C

3.6 Communications

Communication in a team project is very mandatory, because team members work together towards a common goal. It is important to talk to each other and to listen what someone else has to say. Our

team has a team meeting at least twice a week, to keep each other up-to-date of the tasks they are working on but also to brainstorm, to discuss and to give feedback. Supervisors are kept up-to-date through the Wiki page and weekly advisor meetings where they provide us with feedback. It's also very important to communicate with the client, if there are any doubts or other questions we email him or we go to his office at school.

Apart from the oral communication in class and meetings, written communication is also used. A private group on Facebook is created, which we use to write brief messages to each other, such as questions, announcements and small discussions. Together with this Facebook group, the Facebook chat is used for the less important messages.

For sharing documents we use the online tool Google Drive. We created different folders and subfolders in it to keep a good overview. This tool is easy to use and it stores all the documents well organised in the same place. One of the main advantages is that the different members can work on the same file at the same time. You can see precisely where the other one who's working on the file is typing or reading. It's also possible to follow the changes in the recent activity box. This method is not only used in class but also when everyone is home and we cannot talk to each other in person. Everyone from the team has access to it 24 hours a day. Tools such as Skype and Google are very useful to communicate with team members who are temporarily not available to attend the meetings.

Table 11: Communications Register

What	Who	How	When	Why	To whom
Interim presentation	Team	Presentation with PowerPoint giving by the whole team	9/4/2015	Midterm feedback	Advisors & client
Advisor meetings	Team	In person using Agenda on Wiki	weekly	Confirm status of current tasks	Advisors & client
Team meetings	Team	In person, Wiki, Email, SMS and Google Hangouts	Multiple times a week	Teamwork	Each other
Instructions	Arick & Rasmus	Facebook	Weekly	To guarantee progress	Team
Requirements communication	Team	Email and meeting	In case of uncertainties	To guarantee progress	Client

A convenient mental model of communication is indispensable to understand and effectively practice communication. It offers comprehension into the ways in which communication is conceived, designed and enacted. The Shannon-Weaver Model as shown in Figure 2 is one of the most pervasive and influential models of communication. A variation on this communication model is the Project Management Body of Knowledge (PMBOK) model as shown in Figure 3, which follows the same perspective and is more rationalistic. All the components in the PMBOK model need to be considered when discussing project communications. The sender is responsible to provide the receiver with clear and complete information so the receiver can interpret it correctly. The receiver is responsible for interpreting the information correctly and in its entirety. A non-success in the communication can have a negative impact on the project. [N. Grainger P. Marshall J. McKay, 2014]

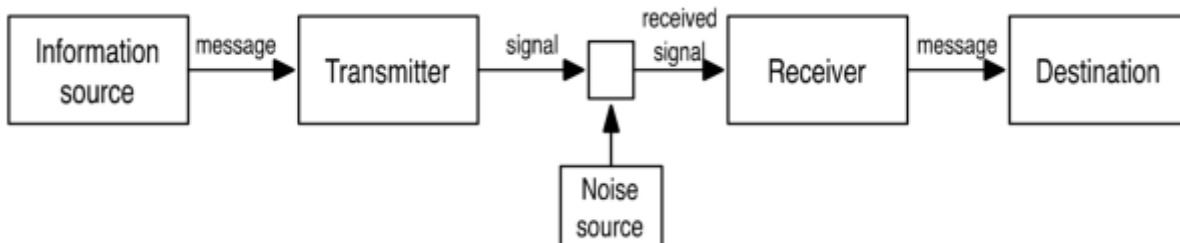

Figure 2: Shannon-Weaver Model

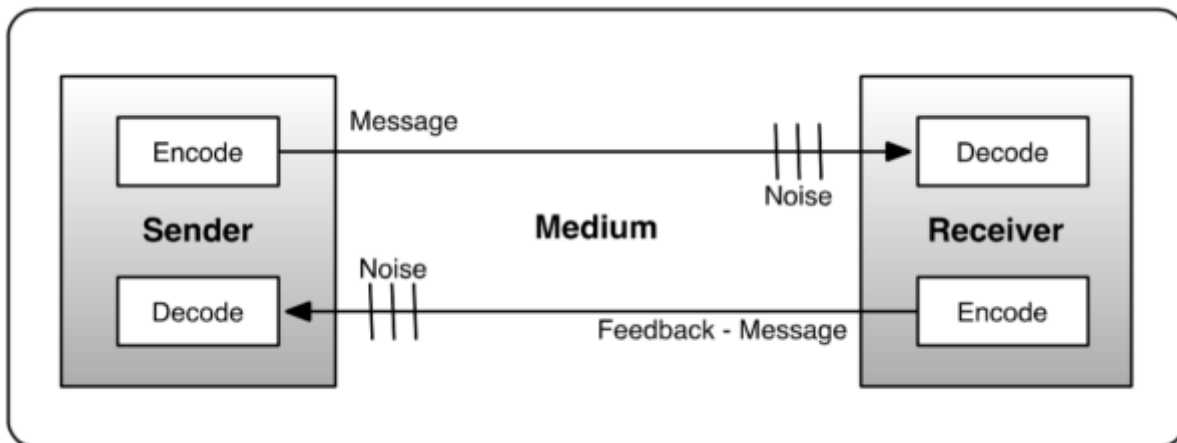

Figure 3: PMBOK Model

3.7 Risk

“A process of risk management in projects is a rational chain of practices taken by decision-agents in order to keep the implementation of the project under certain conditions. The decision-agents need to identify, analyse and evaluate the risks in all project life cycle and use their organizational structure and administrative practices in order to act on the risks in favour of the project.” [J. A. Crispim L. H. Rodriguez-da-Silva, 2014].

Since the EPS product's market launch is currently planned in theory only, risks especially regard to the project development phase. Technical risks are moreover taken into consideration. All team members are seen as decision-agents in this process. Furthermore we consider the project's environment comparable with small and medium enterprises (SMEs). As a definition “SME projects, in general, tend to meet one or of the following characteristics” [J. Kelly A. Ledwith J.R. Turner, 2003].

- They are small.
- They are internal.
- Objectives are concretely defined.
- Team size is very small.
- They are concurrent with the company's daily activities.

We see multiple of these prerequisites complied.

“Identifying risks in the project definition phase is a critical task, since the risks that can be detected are strategic and must be removed before taking the decision to start with the project.” [P. Villanueva A. M. Echeverría Lazcano A. Pérez-Ezcurdia S. Marcelino-Sábada, 2014]. In order to analyse and evaluate the potential risks it was decided to use the Failure Modes and Effects Analysis (FMEA), also

known as Risk Register. This tool makes it easy to include all the necessary data to give an overview about the risks, their possible consequence, the response to be taken and the person in responsibility. As a response there are the options to transfer, avoid or mitigate the particular risk.

Furthermore a Risk Priority Index (RPI) is created, ranking the risks based on the impact as well as the probability to occur. The RPI value is calculated with the following Equation \ref{eq:risk} :

$$RPI = (I_c \cdot I_t \cdot I_s) \cdot P$$

I - Impact

I_c - Cost Impact

I_s - Scope Impact

I_t - time Impact

P - Risk Probability

Next this method is applied in Table 12 to Table 18.

Table 12: Risk Register

Risk	Consequence	Risk Response	Owner	RPI
Components are demolished	Time delay in the construction process and financial shortage	Always handle the materials with care, to avoid these risks. In case of occurrence, discuss with the group about finances or place a new order.	Viorel	0,16
Faulty components are delivered	Time delay in the construction process	Claim the guarantee, send the parts back and get new materials.	Viorel	0,06
Non-functional teamwork	Milestones are not reached. Communication in the group is not satisfactorily performed. The progress is cut down.	Get together to work on communicative problems. Consider the team building measures learned.	Arick	0,12
Customer changes his requirements	The product and its functionalities must be modified. Maybe new parts and materials are needed.	Mitigate; Find a feasible, satisfying solution for the customer within the range of possibilities	Arick	0,16
Team members leave	Task allocation is not appropriate anymore. The human resources might be overloaded.	Transfer the unallocated tasks to other team members and call in supervisors to discuss further procedures.	Arick, Katoo	0,32
Hardware/Data get lost	Time delay in the development process; insufficient equipment to keep working	Avoid high impact of lost by doing frequent backups online	All members	0,12

Following the risks' impact and probabilities were used to calculate the RPI.

Table 13: broken parts

probability-> impact	very low (0.1)	low (0.3)	moderate (0.5)	high (0.8)
very low (0.05)				
low (0.1)				
medium (0.2)				0.16
high (0.4)				

Table 14: **faulty components**

probability-> impact	very low (0.1)	low (0.3)	moderate (0.5)	high (0.8)
very low (0.05)				
low (0.1)				
medium (0.2)		0.06		
high (0.4)				

Table 15: **no teamwork**

probability-> impact	very low (0.1)	low (0.3)	moderate (0.5)	high (0.8)
very low (0.05)				
low (0.1)				
medium (0.2)				
high (0.4)		0.12		

Table 16: **change of requirements**

probability-> impact	very low (0.1)	low (0.3)	moderate (0.5)	high (0.8)
very low (0.05)				
low (0.1)				
medium (0.2)				0.16
high (0.4)				

Table 17: **shrunked HR**

probability-> impact	very low (0.1)	low (0.3)	moderate (0.5)	high (0.8)
very low (0.05)				
low (0.1)				
medium (0.2)				
high (0.4)				0.32

Table 18: **Lost Hardware/Data**

probability-> impact	very low (0.1)	low (0.3)	moderate (0.5)	high (0.8)
very low (0.05)				
low (0.1)				
medium (0.2)				
high (0.4)		0.12		

3.8 Procurement

Procurement is known as acquisition of materials or goods from external sources in a way to keep the

procurement list cost as low as possible without losing quality.

All activities are worked out in Portugal including our client and the project development. Due to restrictions we have from supervisors, we are limited to buy only from Portugal websites or any other local shop, this restriction has a positive part, in case of some product failure we can return products in time. For example, if one of our sensor has a manufacturing defect we can return it and order another sensor in convenient time to finish the project in time.

When we procure online components for our final product we are limited to three websites to keep shipping costs as low as possible and we do other procurements from local shops because not all companies sell their products online [World Bank., 1996].

An important aspect in our procurement list is about quality over cost and we perform purchase avoiding counterfeit products.

Figure 4 illustrates our procurement criteria.

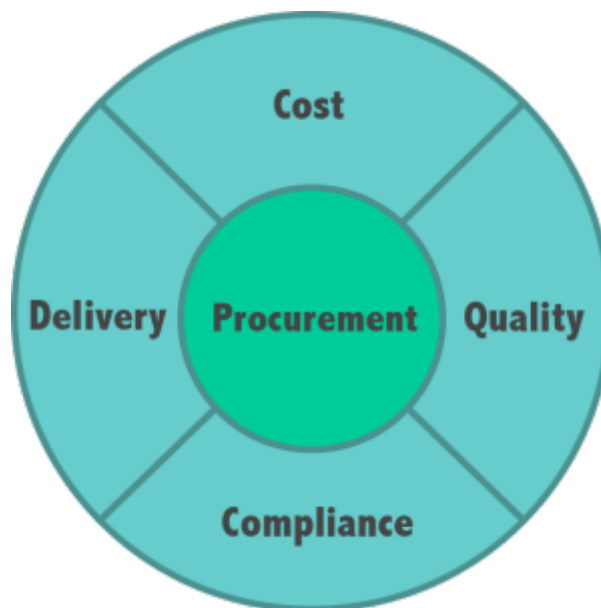

Figure 4: Procurement criteria

3.9 Stakeholders management

Stakeholders management is a process of identifying parties which are somehow involved in the project and have a certain range of power/influence and interest. "The needs and requirement of all stakeholders must be identified and properly managed to better facilitate the development of the project" [Aini Jaapar Mohamed Ali Berawi Hamzah Abdul Rahman Saipol Bari Abd Karim, 2007].

Through this it is possible to develop a strategy that allows us to maintain positive relationship with all of them. As such the process is crucial for effective project management. As stakeholders we mainly identified ourselves as a team, Abel Duarte as our client, Benedita Malheiro as the head of the EPS program and Paulo Ferreira as the supervisor with the greatest interest as well as the greatest capability to help developing our product.

Furthermore there is the supervisor committee evaluating our progress on a weekly base and the teachers who support us to take the necessary steps in order to fulfil our tasks and meet the given deadlines for each subject.

Finally we consider the ISEP itself as a stakeholder due to the fact of the high potential power to have influence on the entire EPS project.

In order to visualise the position of power and interest of each stakeholder regarding our project, a stakeholders register was created. Through this certain strategies for individual stakeholders can be derived. As for stakeholders with low interest and low power we intend to monitor their behaviour,

needs and expectations. This occurs for Supervisors as well as for teachers. Parties with low interest but high power like ISEP should be kept satisfied at any given time. For Paulo Ferreira with still relatively low power but high interest we put effort in keeping him informed about all steps and progress of our project. The team itself with the highest power to influence the project's progress and the highest interest in its success but also Benedita Malheiro and Abel Duarte are the priority stakeholders to handle. The strategy for this section is to manage each party closely at any time and inform immediately if any issue occurs.

Table 19 illustrates the project's stakeholders as well as their power and interests.

Table 19: Stakeholders

Name	Power	Interest	Stakeholders Register
Team	High	High	
Client	High	High	
Benedita Malheiro	High	High	
Paulo Ferreira	Low	High	
Supervisors	Low	High	
Teachers	Low	High	
ISEP	High	Low	

3.10 Conclusion

From the very beginning on it was essential for our group and the progress of the project to keep in touch frequently at all stages of the development process.

On the base of weekly team meetings and vibrant discussions we created a Gantt chart as well as a WBS in order to always ensure a proficient overview of task allocations and deadlines.

Since all team members derive from different fields of studies one of the major challenges was to allocate all tasks in a way everyone had a comparably equal workload. Because of this we already discussed on our first team meeting who could contribute in the most efficient and satisfying way in

order to guarantee the project's success.

By consulting these different tools and methods thoroughly we were able to establish a well working project management process throughout the entire project.

Upcoming we will elaborate the marketing section of our future product.

4. Marketing Plan

4.1 Introduction

The marketing plan is an important part of the project. It is an essential tool for understanding who our target users and furthermore what their needs are. Every part of this chapter is helping us to act proactive in the market.

By analysing the circumstances and conditions in our environment and target market, it will be possible for us to create an individual marketing strategy in order to stand out against the potential competition.

4.2 Market Analysis

In the market analysis we take a look at the macro and micro environment of our company's product and feasible markets to enter. In doing so we identify the existent competition and their strategies and objectives. The performance of potential competitors plays a significant role.

First of all we have to investigate the general conditions our company finds itself in, which is the macro environment. In order to do this sufficiently we examine circumstances such as social, technological, economic, environmental and political. These methods basically aim at the external environment we find ourselves in.

4.2.1 Market Situation

Nowadays people are becoming more and more aware of healthy food and living, especially in the western world, where proportionally more people can afford to take these concerns into account. The sector of organic food and products rose remarkably during the last decade and no end is yet in sight. [\[Helga Willer, et al. Julisa Lernoud, 2015\]](#)

This boost in organic food also contributed to the fast growth of aquaponics systems' popularity. Moreover a reason to own an aquaponics system could be that customers seek to become at least partially self-sufficient to be less dependent on modern food industries.

4.2.2 STEEP Analysis

In order to get a better understanding of the market situation and investigate the macro economical factors concerning our product, we decided to carry out the STEP analysis, extending it to environmental aspects. This analysis allows us to get a sufficient overview of the current market environment.

The STEEP analysis is divided into 5 sections, which investigate on the social, technological, economic, environmental and political factors. Each of these shapes our decisions regarding market

segmentation and launch.

4.2.2.1 Social

The increasing demand on allegedly healthy food led to a fast growth in organic agriculture [Helga Willer, et al. Julisa Lernoud, 2015]. However producing these groceries claim higher expenses that are passed on to the end customers [John Thøgersen Athanasios Krystallis Polymeros Chrysochou Livia Marian, 2014]. Due to these significantly higher prices organic food is, among other things, mostly achievable by higher income households [Karena J. Burke Kylie Dowd, 2013]. Spending more money on groceries and being able to do this can be an expression of wealth and high living standards. Another important point concerning the social factor is the modern food industries which got increasingly into the focus of harsh criticism in the recent past. The aquaponics system offers a brilliant alternative to meet the need of becoming more independent from today's food industry and create self-supplying households. By this means, people can take control of the nourishment they consume and how this is grown. Besides the image of a self-supplying household is also contributing to a reputable social status.

4.2.2.2 Technological

The technological factors play a crucial role within this project. The system that we have designed and built can be declared as a health, self-supply appliance based on electrical tools and resources. It contains many sensors and functions on a web-based monitoring base. This is the reason why modifications and shifts in this field affect costs and quality and can also involve vast innovative changes.

4.2.2.3 Economic

The development of the organic food market worldwide and on our targeted specifically can be roughly used to determine the economic appeal of aquaponics systems and hereby involved technologies.

The total market size of the organic market rose from 15.2×10^9 USD in 1999 up to as much as 72×10^9 USD in 2013. The land on which organic food is cultivated increased from 11 million hectares to more than 43 million hectares in the same period of time, only representing 1 % of the total agricultural land in 2013 [Helga Willer, et al. Julisa Lernoud, 2015].

This high price food sector [John Thøgersen Athanasios Krystallis Polymeros Chrysochou Livia Marian, 2014] finds its biggest markets in USA contributing 24.3×10^9 €, Germany (7.6×10^9 €) and France (4.4×10^9 €). [Helga Willer, et al. Julisa Lernoud, 2015]

4.2.2.4 Environmental

As most aquaponics systems, especially in private households, are used indoor weather conditions have almost no influence whatsoever on the maintenance of these plants.

One of the major aspects of aquaponics system regarding environmental factors is the savings on water consumption within the production process. There is almost no additional wastage to supply water for the plants because of the circulatory symbiotic relationship of the aquaculture and the

hydroponics units.

Nowadays already about 70 % of the fresh water worldwide is used for agriculture. Additionally as much as 85 % of the world's fish population is overfished. [Clemens Weiß, 2015] This points out the need of alternative solutions.

Moreover aquaponics systems entirely avoid the exploitation and pollution of soil. These self-sufficient structures set an example on production efficiency combined with low effects of ecological footprints.

4.2.2.5 Political

Since our system involves a web-based technological gadget targeting domestic use of aquaponics or similar systems, there are no political regulations in place that need to be analysed more profound. Eventually, on specific markets there exist political funds to subsidize start-ups focussing on sustainable, organic food production.

4.2.3 Competitor Analysis

By now there are several providers for aquaponics systems on the American, European as well as international market.

However only few concentrate on controlling and monitoring and even fewer focus on web-based models or apps to execute these tasks.

We are going to look at the some major of these specialised ventures closer in the course of the competitor analysis.

4.2.3.1 OsmoBot

OsmoBot is a US-American company, which developed a controlling device especially for aquaponics system [Osmobot, 2015]. They built an all-in-one gadget to record several data. These include pH-value, dissolved oxygen, water & air temperature, water level, relative humidity as well as light spectrum.

The data can furthermore be supervised via local networks or more distanced via an app by tablets and smartphones.

The system also includes a warning messaging service in case specific values reach a critical level.

OsmoBot has not launched markets yet and is planning on doing so in the middle of this year.

Additionally OsmoBot is planning on extending their system by gadgets to measure ammonia and nitrate.

The starting price for the basic device is 499 USD, the extra equipment for ammonia and nitrate is aimed to cost 399 USD each.

4.2.3.2 Cooking Hacks' Open Aquarium

Open Aquarium is a system built and distributed by the Spanish electronics store Cooking Hacks, located in Zaragoza [Open Aquarium, 2015].

The system is based on a basic and an aquaponics kit as well as several extra devices that can be additionally purchased. The basic sensors measure pH-value, conductivity, temperature, water level and possible leaks. Moreover the system includes automotive functions such as there are a food

dispenser, water temperature regulator, water pump and light.

The aquaponics can be monitored and controlled via a web based application, which furthermore runs on Apple as well as Android devices. The basic kit is not kept as small and handy as the OsmoBot device but brings focus into the pragmatic part of aquaponics systems.

To run all these functions properly it is necessary to buy the basic as well as the aquaponics sensor kit. These cost 298 € (199 € & 99 €).

4.2.3.3 Sensaphone

Sensaphone is a US-located company which focusses on remote monitoring and alarm functions [[Sensaphone, 2015](#)].

The main focus does not lie on aquaponic systems but on general solutions. Values such as humidity, air pressure, water flow and temperature can be monitored and trigger an alarm on phones when a certain limit is exceeded. Furthermore power, water pump and air blower can be switched on or off remotely.

Additionally Sensaphone provides their devices with a backup battery to assure functionality in case of a power breakdown.

The simplest device to use for aquaponic systems starts from 749 USD.

4.2.3.4 Major/minor competition threat

OsmoBot and Cooking Hacks don't show a real gap when it comes to prices. Sensaphone is a typical higher priced competitor from outside of the aquaponic industry.

Open Aquarium offers a higher degree of flexibility and individualisation due to the fact that several components can be purchased additively.

All of our main competitors' tools have similar functionalities as our system is going to have.

The crucial differentiation criteria though is, that we basically offer all functionalities in one single device.

Our product combines the aesthetic design as well as the web-based monitoring for mobile devices which OsmoBot offers and furthermore includes controlling devices such as the food dispenser, water pump, temperature regulation and light switch which is partly covered by the Open Aquarium gadgets. Furthermore the functionalities are far more complex than Sensaphone's devices at a much cheaper price.

4.3 SWOT Analysis

The SWOT analysis is a planning tool which helps us to identify **S**trengths, **W**eaknesses, **O**pportunities and **T**hreats the product or company is facing on the emerged markets.

- Strengths are attributes of our team/company that provide us with a competitive edge over other enterprises.
- Weaknesses are attributes of our team/company that could signify disadvantages on our side compared to others.
- Opportunities are features we could use to create additional value and doing so giving us advantage.
- Threats are circumstances that could possibly cause difficulties for the project and our objectives.

The following figure [jisc infoNet, 2015] implies how these characteristics can and should be used in an optimum way.

Figure 5 Shows the task derivation of the SWOT analysis. Afterwards the analysis approach regarding our system is illustrated in Table 20.

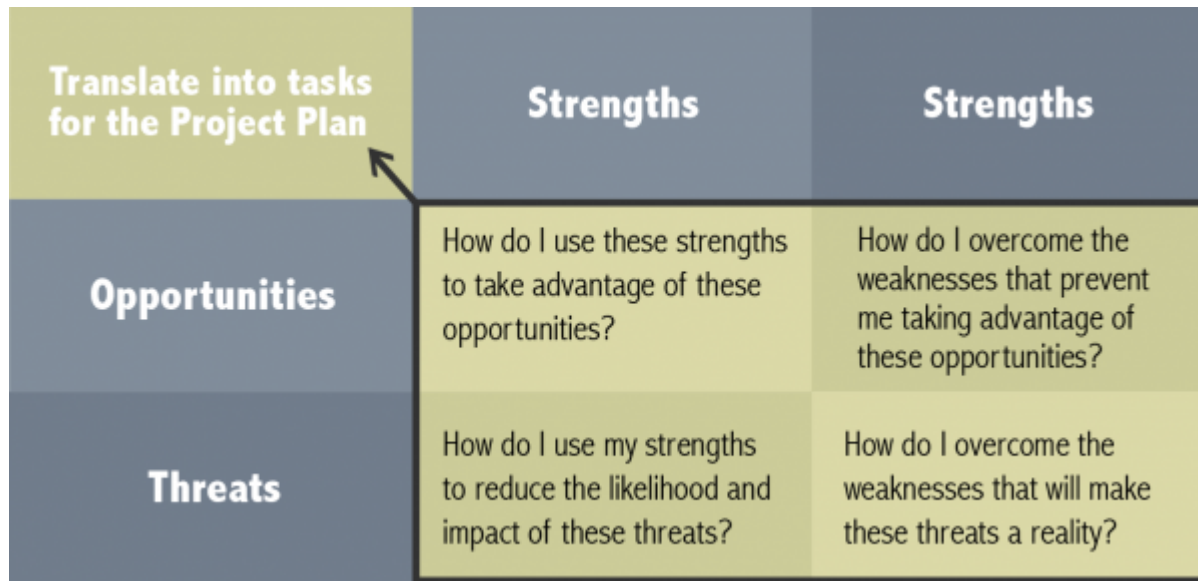

Figure 5: SWOT

Table 20: SWOT Analysis

Strengths	Weaknesses
multilingual and -cultural team	limited budget
diverse knowledge	limited developing time
customizable product	new company
self-sustainable and eco-friendly	lack of market experience
easy to install	less appealing than iOS or Android Apps
broad functionalities	
cost-effective	
low expenditure of energy	
webpage-based	
Opportunities	Threats
quickly achieve large market share internationally	experienced competition
high growth rates in aquaponics worldwide	fast and vast launch of competitor's product
reasonably priced system	saturation of the market
great market potential	relatively easy to copy -> no patent protection
attraction of less technical affine users	loss of app-favouring customers
attraction of potential customers without smartphones/tablets	

4.4 Strategic Objectives

In our first year we will target our product on the German and French market. This is primarily because of the high potential purchasing power with focus on the organic food sector as mentioned earlier in the market analysis. Researches show that the demand is high in these countries.

In the second year we want to extend our market share and acquire new European markets. We will observe very closely the evolution of Aquaponic Admin and monitor options in different European countries. So we can decide on which countries we will focus. This mainly depends on the feedback and potential customer groups.

In the next year we will launch our product in the USA and Canada after finding American distribution partners.

We are furthermore constantly seeking to improve our service approach to our customers because the customer relationship management is essential to us and the sustainable success of our product.

4.5 Segmentation

For the cause of the market segmentation we are having a closer look on 3 major differentiations. Demographics focuses on the customers' characteristics such as age, income and gender. The psychographics part takes attitudes, values and personality into account and the geographic section obviously works on the geographical scope of our target market. Considering these features of our target group we can moreover derive the markets into smaller segments and devolve this knowledge to specify the scope of our future marketing operations. During this step we have to distinguish between:

- Mass Marketing: undifferentiated, all products, distributions and marketing aims to every person.
- Segment Marketing: differentiates different market segments. Further subdivisions can be concentration on only one segment, selective specialism or product specialization.
- Niche Marketing: high degree of specialization on particular submarkets and/or clearly defined target groups.
- Micromarketing: also known as individual/local marketing. Highest degree of specialization, dissection of the market until the individual customer and his personal needs. -> "tailor marketing"

4.5.1 Demographics

Following an online survey in connection with commercial aquaponics production states that the mean age of the attendees was 47 ± 13 years with a range from 18 to 72 years. Furthermore a majority of 77 % within the group of participants was male. [Richard E. Thompson Ken Semmens Laura Genello Elizabeth S. Hill Ximin Li Jillian P. Fry David C. Love, 2015] These data give a proficient overview about age and gender of our targeting group. Since our system also intends to provide people with organic food who usually can't afford organic agricultural products, it aims at high and middle income but also at lower income households. A certain amount though must be contributed to build up the aquaponics system. Our clients who mainly purchase the monitoring devices for the reason of absence from their systems can be assigned to the middle and high income section.

4.5.2 Geographics

Regarding the geographical classification of our future customers we mainly focused on the biggest markets for organic foods worldwide. [Helga Willer, et al. Julisa Lernoud, 2015]

This statistics show that the vast majority of retail sales of organic food takes place in industrialized countries within North America and Europe. Moreover the 10 countries with the highest per capita consumption of organic food is found in these regions.

These findings clearly emphasize the importance of Europe and North America as present and future markets for agricultural products and coming from this, for aquaponics systems and associated technics.

4.5.3 Psychographics

Concerning the attitudes, values and personalities of our clients it is not possible to draw an exact conclusion.

But there are certain specifics we're aiming at. First of all the client should have an aquaponics system, comparable plants or is interested in purchasing or building one.

This can be for reasons such as health consciousness, the desire to be self-supplying, general interest in the field of aquaponics and aquaculture or simply the wish to produce food with one of the most sustainable methods.

Our main customer has an awareness on environmental issues, cares about his surrounding and is furthermore interested in sustainable progress.

Another fact, independent from these characteristics is the possession of an internet enabled device such as a smartphone, tablet or computer so the consumer can actually use the web-based service which comes with our instruments.

4.5.4 Conclusion

All these information result in a more or less clear target group regarding our product. The majority of our clients is male and between 18 and 70 years old, located in the western hemisphere.

Our customers are interested in alternative methods of organic agriculture and partly technophile, possessing computer devices with internet access. Also they have the need of being able to supervise their systems even if they're not possible to be physically on spot at all times.

The entirety of these cognitions implicates that we follow up a niche marketing.

4.6 Strategy/Positioning

Positioning implies the consistent tracing of a clear, unique and desirable position in the performance of the target segment compared to the competitors.

"An effort to influence consumer perception of a brand or product relative to the perception of competing brands or products. Its objective is to occupy a clear, unique, and advantageous position in the consumer's mind." [\[Business Dictionary, 2015\]](#)

The positioning strategy scan can be divided in 3 stages:

- Identifying possible competitive advantages
- Choosing the appropriate advantages
- Representing the choice in the most convenient way

Figure 6 shows the approaches to identify possible competitive advantages and from which section of differentiation these originate.

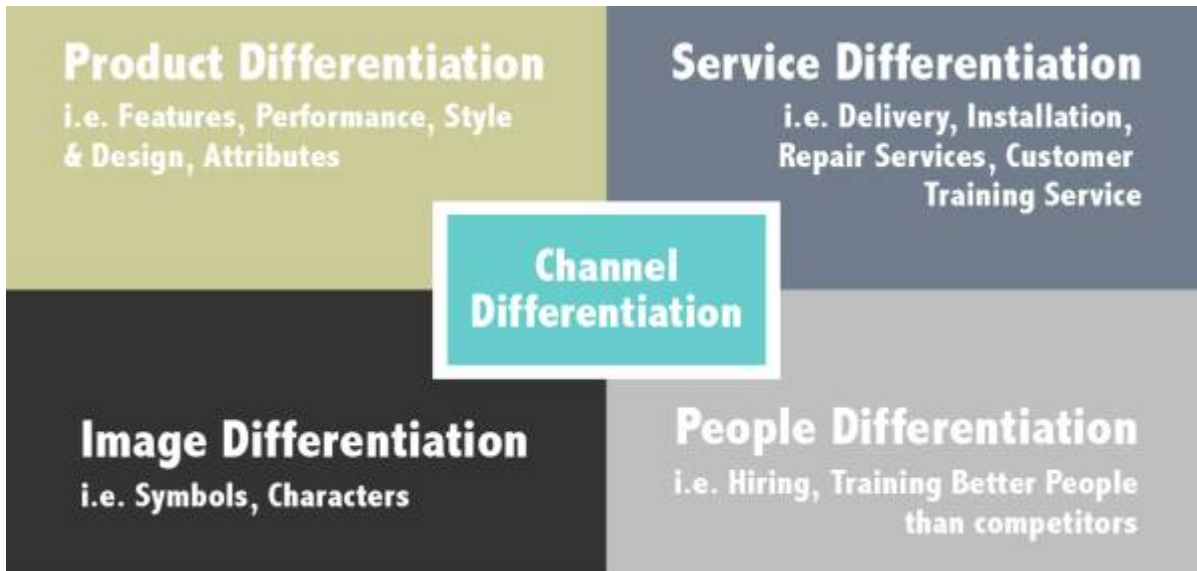

Figure 6: Identifying Competitive Advantages [[Andreia Taveira da Gama, 2015](#)]

To elaborate this task, we can have a look back at the SWOT analysis and screen our most precious characteristics that give us the advantage we need to succeed over our identified competitors.

We can filtrate specific Strengths on all levels.

The aesthetic design we strive for and the extremely user-friendly performance of our system stand for the product differentiation. Comparable to Apple's iPhone, we work on a foolproof display control, without neglecting sufficient complexity of our systems.

Additionally the installation is supposed to be as easy as possible in order to reach customers without a professional technical background. We can furthermore distinguish over a redemption service which comes straight with our sustainability policy.

Moreover we represent a young, vibrant, international and highly motivated team and this is greatly communicated through our product as well as company vision and mission. As a result we can create the image of a self-confident, reliable start-up.

Figure 7 illustrates our targeted product placement regarding to the major important criteria user-friendliness and scope of functionality.

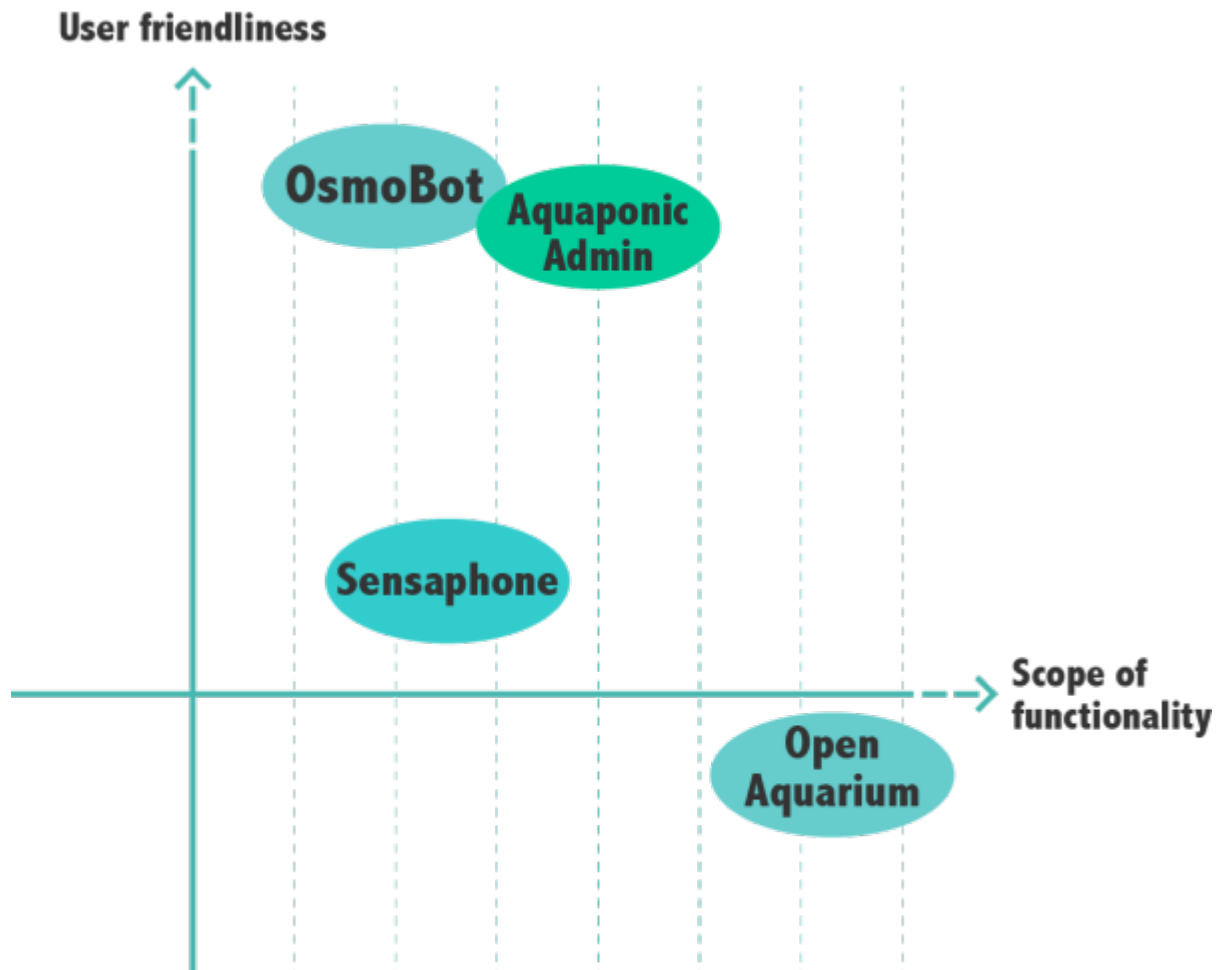

Figure 7: Distinguishing from the competitors

Our objective is to present the market an integral system. It aims at more potential costumers than each of the competitors because we can introduce a system combining all positive advantages without give up on any extras. Our solution makes aquaponics system and the monitoring and controlling which comes with it a cool hobby for a wide range of clients.

4.7 Adapted Marketing-Mix

The Marketing-Mix is a method to implement marketing plans and strategies into concretely measures. In the classical conception it basically consists of the 4 **P**'s which are **P**roduct, **P**rice, **P**romotion as well as **P**lace. Nowadays some add more P's such as People, Processes, or Physical to the method. These broader definitions are mainly used for services marketing and since our product is a consumer good, we only take the classical variation into account.

Figure 8 shows the classic approach towards the Marketing-Mix.

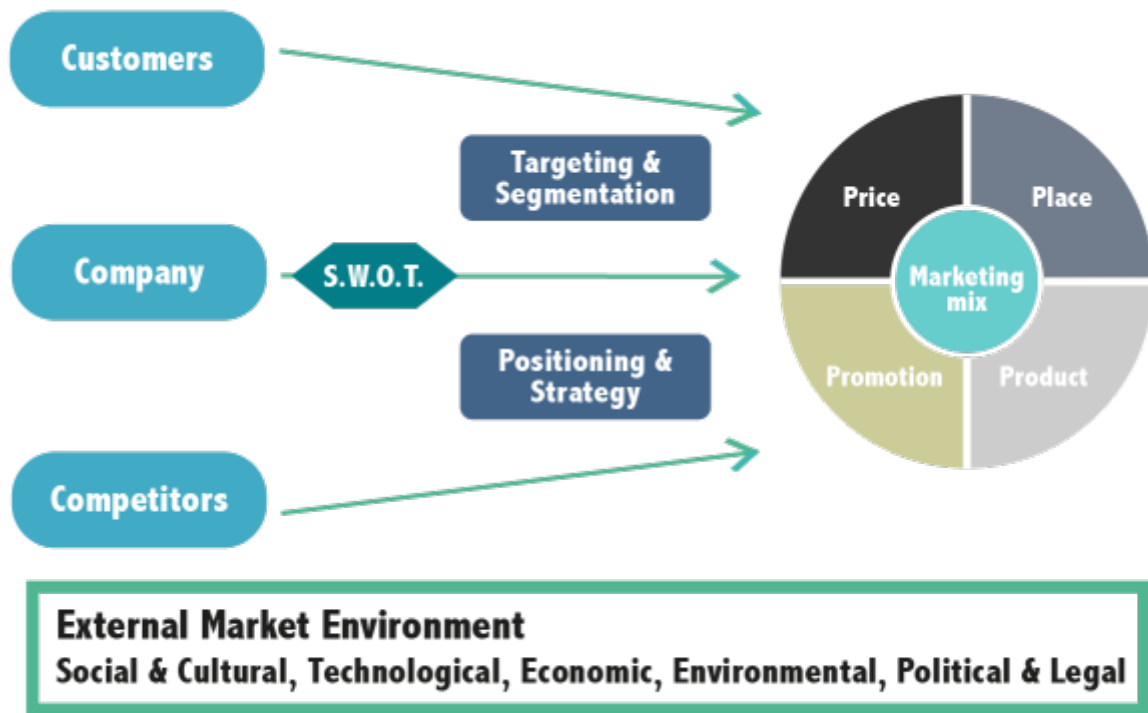

Figure 8: Marketing-Mix Approach

This phase of the marketing approach can be seen as the decision-making step in which we actually choose the way to put our product on the market and is the last step of our marketing measures. So far we analysed the market environment, examined prospective target groups as well as the main competitors which frame the state of the art in aquaponics monitoring. We furthermore ran a SWOT analysis and on base of all these criteria chose a positioning which would best fit our product and targets. The next step will consider how to put our product in the best circumstances of product, price, promotion and place to be successful in the most efficient manner.

4.7.1 Product

Product is defined as “a bundle of attributes that target the generation of customer benefits (of any kind).” [H. Krohmer Ch. Homburg, 2009]. So the customer benefit is pointed out as the desirable achievement.

Components of the product are e.g. core functionalities, additional features, packaging and design, basic services, value added services and the brand itself. Goods can be divided into service goods and material goods. In this case we want to launch a material good, more specific a consumer good.

The systematization of the decision fields of the product policies are innovation management, management of already entrenched products and the brand management. Innovation management is all about the process of research and development of a new innovative product as well as the market launch until the turnover outruns the research and development costs. From this point on, a product is considered as entrenched. The brand management takes place from the first launching steps of a product on the market until the very end of its lifecycle.

We are dealing with the innovation management as well as the brand management. This includes gathering ideas, defining the concept, evaluating the concept and finally launching the market. These stages have partly been undertaken by our client and supervisors already. We further defined and

developed the final product on the basis of the state of the art and the market analysis.

In order to successfully assert oneself on the market, we want to cover the gap between high functionality complexity and user friendliness. Our product strategy includes a high grade of customer support and high quality components to ensure a long-lasting, sustainable system. It offers great savings on energy consumption due to most efficient adjustments. With the goal to achieve a long-term relationship with our customer and open up a different source of income, we will be responsible of taking back broken or old parts. This also contributes to the eco-efficiency and sustainability concept.

By creating a catchy but simple logo as well as a brand name which is able to transfer our product's message easily, we make sure potential clients show interest in what's behind this appearance. A brand is described as “an idea embedded to a customer's consciousness that differentiates a company's quotation from the competitor's quotations.” [H. Krohmer Ch. Homburg, 2009].

The main questions that need to be answered in terms of brand positioning are 'who am I?', 'what do I offer?' and 'how am I?'.

By implementing the product with an appealing logo and brand message, we make sure to create a positive and attractive consumer attitude. The logo design and progress is further illustrated in chapter 7.4.

The final logo contains a fish and plant who are connected with hexagons and the product name: Aquaponic Admin. Two colours are used with the code: #26999E (blue) and #77AD82 (green). The used font is PT Sans, it is sans serif and bold.

Figure 9 illustrates the final version of the logo.



Figure 9: Final logo

4.7.2 Price

The next section deals with **price** policy. It is understood as “the policy by which a company determines the wholesale and retail prices for its products or services.” [Business Dictionary, 2015] The pricing policy has 4 major characteristic features:

- rapid feasibility
- complicated revision

- large impact force
- high impact speed

Our product will be offered through the strategy Configure to Order (CTO). The client is able to choose the sensors and abilities of his product from a selection of elements which are on stock at our company. Due to this service we can guarantee faster deliveries and an increase in manufacturing efficiency. It furthermore contributes the advantage that more customer wishes are fulfilled by only one base product. Costs will be higher than in mass production but we can guarantee a high feeling of individualism through this strategy.

There are mainly two strategies regarding the price determination of new products. These are called price skimming and penetration. Price skimming implements a relatively high price for a product during the market launch in order to skim the customers' willingness to pay and due to this quickly redeem investments on R&D.

Price penetration implements a relatively low price with the goal of a rapid diffusion in the market which leads to the achievement of large market shares.

In terms of our product it will be launched through the price penetration. This is one of our main competitive advantages compared to others. With material costs of less than 250 € it will be possible for us to offer the system at a relatively low price. This means that the price will be cost-oriented. When it comes to discounts it will be possible to renounce standard postal charges and offer an express service provided by an external service company on base of an extra charge.

For direct purchase demands due to trade fairs we will be able to offer a certain discount due to savings on shipping costs. Since we're mainly targeting private households which demand one system each, there'll be no bulk discount planned.

In terms of payment customers will be able to choose between two different methods. Paying by credit card will be one of them, because it is a fast and reliable way of transfer. Due to the fact that our first launch target market is located in Europe it will be moreover possible to use PayPal as a payment procedure. This can be explained through the fact, that in Europe less people possess credit cards than e.g. in the USA.

4.7.3 Promotion

Further we need to consider the **promotion** policy, also called communications. It is concerned with the advertising media, the advertising materials and the most cost-efficient way to combine these with the overall target to maximize the company's turnover.

According to [\[Voet van Wanderschoot, 1992\]](#) this personal or mass communications are "efforts that mainly aim at announcing the offer or maintaining awareness and knowledge about it; evoking or maintaining favourable feelings and removing barriers to wanting."

The most common model to describe the phases the future consumer should run through is the AIDA model. It basically is an operation principle to explain the wished achievements of promotion sales actions. Initially potential clients' **A**wareness/**A**ttention needs to be arrested, e.g. by catchy advertisements. Then the client must evolve an **I**nterest in the product. This can be achieved by conveying emotions and persuading the viewer of the needs our product meets. In the third step the customer has to evolve the **D**esire to possess the good in order to lead to the last step which is **A**ction, the client purchases the good.

Nowadays the AIDA model is often extended by the feature **S**atisfaction. This AIDAS aims to satisfy the customers on long-term and through this generating a sustainable relationship with the clients on the base of satisfaction and loyalty. This system will be playing a major role in our marketing mix, as it is essential for the long-term success of our product to generate a loyal circle of customers.

Figure 10 shows the extended version AIDAS.

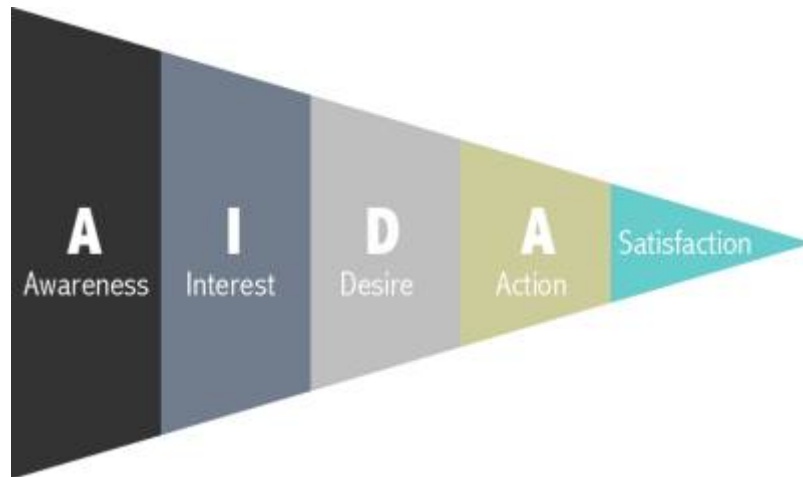

Figure 10: AIDAS model

There are several tools for promotion sales in order to fulfil this procedure. The classical tools are print media, TV- and cinema advertisements, radio advertising and outdoor advertisement such as posters and advertising pillars.

Further communication tools are online, mobile terminal devices, trade fairs, events, direct marketing, corporate identity, product placement, public relations and sales promotion/merchandising.

Following Table 21 will explain more precisely the features, advantages and disadvantages for some of these media.

Table 21: Advertisement Media

	Print	TV	Radio	Outside	Online	Mobile	Direct Marketing
Advantages	exact timing	high availability (most households have TV)	regional segmentation	young, mobile classes can be reached	personalisation	location-independent	individuality
	short-term calculability	intensive usage of TV	low price	effective use for regional or local ads through precise placement	interactivity	reachability	advertisement success is easily measurable
					integration with other media and functions e.g. QR-Code	personalisation	
					multimediality	interactivity	
					actuality	localisation of user	
			high reach		advertisement success is easily measurable	viral effect	
					good reachability of young target groups		
					usage of own homepage for communication purposes		
		usage for viral marketing					

	Print	TV	Radio	Outside	Online	Mobile	Direct Marketing
Disadvantages	high divergence loss	aimed target group is rarely reached	missing visual design possibilities	short period of consideration	enhanced reactance	enhanced reactance	enhanced reactance
	inaccurate address of target group	declining acceptance of TV ads at high costs	listeners pay little attention		not all classes are reached e.g. elderly people	relatively high thousand-contact price for push-campaigns	

As we're offering a system to be monitored and controlled via internet, it is inevitable for our customers to have frequent internet access. This makes online and mobile advertisements more attractive because our target group is definitely reachable throughout this media. Moreover the targeted client has much specific interests and hobbies, this leads to the conclusion that TV advertisements as well as radio-spots are covering a wide range of people but only a fraction of these are potential clients. The costs for such commercials are incommensurate with the expenses and therefore not part of our marketing approach. The same applies for outside media such as advertisement pillars. Radio and outside advertisements are moreover too regional linked. The used media have to reach its clients nationwide in order to generate sufficient turnover.

Direct marketing can save costs by only contacting potential customers. Information for these recipients can be gathered e.g. on trade fairs. Additionally, newsletter e.g. via our web presence are an obvious way to get and stay in direct contact with our customers. Print media can be somehow expensive but make sure to reach a defined specific group of readers. In order to develop awareness and arouse interest towards our brand and product we will place advertisement in magazines which deal with similar fields such as gardening, aquaculture, fishkeeping and hydroponics. Especially e-magazines are a good alternative choice from paper-based media. As a measurement of sustainability we will reduce the wastage of additional leaflets and flyers as far as reasonable.

Our main field of action will be online, whether on social media and other websites or mobile devices such as smartphones and tablets. Due to this we can assure, that the advertisements reach the potential target group in a swift and contemporary way. Moreover the customer is confronted with our product directly on the device it will be used in the future. Thereby it is possible to introduce samples of our website and their functionalities virally as well as virtually. Moreover the success rate of these channels are relatively easy to comprehend and trace. This enables us to place customised ads for specific end consumers.

One of the most important channels to communicate our brand, product and message are trade fairs. Through the much specific fields of exhibitions we will be able to present in an environment containing the highest share of potential customers to find anywhere. These measurements will be further treated in the place marketing division.

4.7.4 Place

Now we proceed with the right choice of **place** and distribution of our Marketing-Mix. When it comes to the field of place there are three major decision panels. These are organisation of the distribution system, organisation of the sales activities and the arrangement of the relationship structure towards the distribution partners and key accounts.

The distribution system consists of the elements distribution institution and distribution channel. The institutions are combined to channels. The sum of these distribution channels result in the distribution system. Distribution institutions can further be divided into internal and external units. The internal units are either organisational departments or individuals like key account manager, sales director and general manager. The external units are either company linked like distribution partners and franchisees or units which are independent from the company. These are either intermediaries like the wholesale and retail or sales assistant like brokers, logistics provider and trade representatives. On the side of the distribution channels there are two ways to proceed. This is operated either through direct or indirect distribution. Indirect distribution takes place if external distribution partners take on a major functional role in the acquisition of the product's commercialisation.

Table 22 outlines the advantages and disadvantages of either distribution channel decision.

Table 22: Distribution Channels Comparison

Distribution Channels	Advantages	Disadvantages
direct	immediate control of the distribution events	high own organisational effort in distribution
	immediate communication with end consumer	mass distribution is not possible
indirect	broad mass distribution is possible	no immediate access to the distribution events
	shift distribution function to intermediary	complicated communication with end consumer / no personal presence at sight
	performance on newest technological standards	potentially different interests of manufacturer and distribution partner
		manufacturer has to rely on the distribution partner's competence

Since aquaponic systems and likewise our monitoring system are not demanded on a mass production base yet and CRM has a major role in our development plan, we will rather choose direct distribution channels. Furthermore immediate controls of distributions are essential to guarantee a successful launch of the product and future business.

This is why we will focus on direct marketing in the first place.

The arrangement of the relationship structure towards the key accounts will not be a significant part for our company since the monitoring system targets mainly private households and even when used on a business base there's no scope for large sales because several monitoring systems are not required.

In order to run online distribution successfully we will need a logistics parcel service partner. Possible partners are DHL, UPS, Hermes and DPD offering several business targeting services.

Concerning the organisation of the sales activities we have to answer the question how to arrange the contact to the end consumer. These contact approaches are generally divided in three possible types. They are either personally direct via field service, trade fairs or stationary retail markets; personally medial via phone or video conference; or impersonally medial via TV, mailing/catalogues or internet [H. Krohmer Ch. Homburg, 2009].

As mentioned earlier on in this report, we are counting mainly on direct personal contacts on trade fairs as well as medially spread communication on base of internet ads and presence.

Table 23 shows trade fairs to present our product during the first months after launching Aquaponic Admin. Dates in italic are not yet finally confirmed.

Table 23: Potential Trade Fairs

Trade Fair	Type	Location	Date
Univers Jardin Sainte-Maxime	Exhibition for sustainable and eco-friendly gardens	Sainte-Maxime, France	Jun 2015
Innov-Agri Outarville	International Agriculture Fair	Outarville, France	Sep 2015
Euro Gusto Tours	European trade fair for Slow Food	Tours, France	Nov 2015
Naturellia La Roche-sur-Foron	Exhibition for organic products	La Roche-sur-Foron, France	Dec 2015
Bio Harmonies Montpellier	Fair for Organic Products	Montpellier, France	Dec 2015
Aqua-Fisch Friedrichshafen	International Specialized Exhibition for fishing, fly fishing and Aquatics	Friedrichshafen, Germany	Mar 2016
Angeln & Aquaristik Freiburg im Breisgau	Fair for Aquarium	Freiburg im Breisgau, Germany	Mar 2016
Aquaristika Leverkusen	Fair of aquarium accessories	Leverkusen, Germany	Sep & Dec 2015
aqua Expo Tage Dortmund	Aquarium fair	Dortmund, Germany	Oct 2015
Aquaristik Tage Ulm	Aquarium fair	Ulm, Germany	Oct 2015
Aquaristik- und Terraristikbörse Estenfeld	Exhibition for aquariums and terrariums	Estenfeld, Germany	Oct 2015
Aqua Terra Berlin	Fishkeeping and terraristics fair	Berlin, Germany	Nov 2015

Since the customer relationship plays an essential role, we further emphasize the planned strategies. Based on [H. Krohmer Ch. Homburg, 2009] we take a look at possible measures in order to tie customers. In the following Table 24 we will mark our intended measures in bold on the base of our goals and possibilities.

Table 24: Customer Relationship Management

		primary orientation	
marketing mix section	focus: interaction	focus: reward	focus: change barriers
product	involve the customer in the product development	customer individual product adjustment	products are not compatible with competitor's products
		complimentary supplemental service	performance guarantee
price	price concessions during negotiations	quantity discount	price guarantee
		loyalty discount	
		bonus programs	
promotion	callcenter-/ service number	customer magazines	advertisement contracts with processors (Cobranding)
	customer forum/customer advisory council	invitations to special events	
place	sales force visitations	24-hours service	long-term delivery contract/subscriptions
		express delivery	customer-oriented locations

4.8 Budget

During the first year of our product launch our marketing budget cannot be more than 5000 €. We decided to only attend 8 fairs, because of time overlapping which could exceed our human resource capabilities.

Furthermore we will be present in the two major fishkeeping printed magazines in France and Germany. Leaflets will moreover be printed to hand out at trade fairs.

For these it is also necessary to bring and install a display system to show to our potential customers and other groups of interest. Our online performance will be spread over Backyard Aquaponics' eMagazine, the largest of its kind as well as through social media appearance and our own homepage, where interested parties can access all the information necessary to get to know our system. To additionally reach smartphone users there will be advertisements displayed on two large applications regarding aquaponics and alternative gardening.

The following Table 25 gives an overview of the aimed marketing expenses.

Table 25: Budget Allocation

Print	Price [€]
Fair Leaflet	80
l'aquarium à la maison	320
aquaristik - Aktuelle Süßwasserpraxis	320
Online	
Backyard Aquaponics - eMagazine	400
Homepage Maintenance	200
Social Media	160
Mobile	
Aquaponics Digest Magazine, Organic Gardening Technology	150
The Dirt on Organic Gardening Magazine	150
Direct	
8x Fair Transportation	1600
8x Fair Stand	1200
Display System	250
Sum Total	4830
Backup	170

4.9 Strategy Control

In the current business environment characterized by fast changes in customers, technologies and competition, organizations need to continuously renew themselves to survive and prosper [E. Danneels, 2002].

In this chapter we take a closer look at the Management Control Systems (MCSs), in order to make possible success or failure measurable and due this take actions in future decisions.

After the steps of plan development and implementation, controlling is performed. Standards are compared to de facto results. Following the results are evaluated and a decision is made on how to proceed.

As long as the deviation is within acceptable borders, nothing will be undertaken. Otherwise corrective measures need to be executed.

These can either lead to the new development or an adjustment of marketing strategies or has direct influence on the running business presence on the market.

Figure 11 illustrates these mentioned steps and measures.

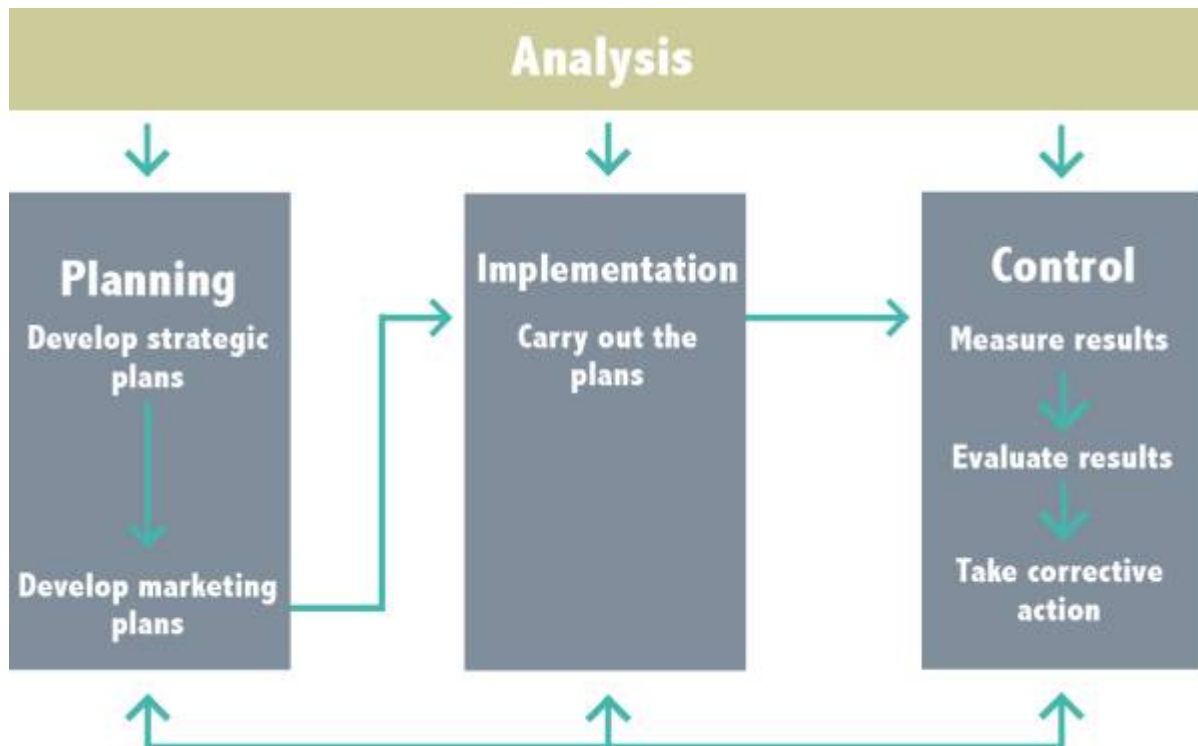

Figure 11: Strategy Control

All marketing strategies and planning have to be analysed e.g. after a certain period a product was launched on the market. MCSs include measurements, evaluation and monitoring. “MCSs are define broadly to include everything managers do to help ensure that their organization's strategies and plans are carried out or, if conditions warrant, that they are modified.” [Van der Stede Merchant, 2007].

One way is to measure the advertising, sales force or distribution efficiency and how different channels could convince customers to a purchase decision.

Following we will introduce some measures that can be taken in order to monitor the different efficiency approaches by [I.M. Crawford, 1997].

According to [R.F. Hartley, 1979] sales force efficiency indicators are generally:

- Average number of calls per salesperson per day
- Average sales call time per contact
- Average revenue per sales call
- Average cost per sales call
- Percentage of orders per 100 sales calls
- Number of new customers per period
- Number of lost customers per period
- Sales force cost as a percentage of total sales.

Advertising efficiency can be tracked with the following key indicators:

- Advertising cost per thousand buyers reached overall, for each media category, and each media vehicle
- Percentage of audience who noted, saw/associated, and read most for each media vehicle
- Consumer opinions on the advertisement content and effectiveness before/after measures of

attitude towards the product

- Number of inquiries stimulated by the advertisement
- Cost per inquiry.

Distribution efficiency measures are mainly taken through statistical/operational research methods such as:

- Inventory control
- Warehouse location
- Transportation methods - optimum routing, scheduling, loading, unloading.

In order to find this out, we will use e.g. click trackers for online and mobile advertisements and actual purchasings as a percentage of interested clients. On trade fairs we can measure sold products over the total amount of requests and finally break down to expenses compared to success so we can adjust the strategies to the most efficient settings.

Information can be delivered through a Management Information System (MIS). This system is “used to provide management with needed information on a regular basis.” [Mary Coulter Stephen P. Robbins, 2010]. These information basically is data which has already been analysed and organised such that it has value and relevance to managers.

4.10 Conclusion

Completing the marketing section, we can summarize that our product has a defined target group to aim at, the external as well as the internal environment have been analysed and a strategy for further business steps was developed.

Furthermore we laid our main focus for advertisement and distribution on direct and online channels, which in the future makes it relatively easy to monitor and control and as a result we will be able to operate our business in the most successful and efficient way.

Coming up in the next chapter we will discuss the different approaches on the Eco-efficiency Measures for Sustainability in general and our intended methods and actions.

5. Eco-efficiency Measures for Sustainability

5.1 Introduction

Aquaponic systems inherently offer environmental, economical, and social benefits. The addition of our remote control capabilities makes the system more efficient from the perspectives of power and energy consumption. As a result of improved efficiency, electrical power consumption is reduced. Ensuring the system functions properly reduces operating cost. The remote access allows the user to have more time for other responsibilities and not have life interrupted by their aquaponic systems. In order to effectively implement eco-efficiency and sustainability we consider the importance of the production and delivery of our product. These measures include where we procure our components, where we produce our product, how we distribute it and who we hire. These are all key topics for maintaining sustainability.

5.2 Environmental

Our aquaponic system is formed by many electronic components. Making these electronic components produce damage to our environment, therefore we have to find products that respect the environment. This section will discuss how to achieve a sustainable product. We rely on three environmental standards: energy, climate and greener products.

- **Reduction of greenhouse gases (GHGs).** We have to eliminate hazardous substances from our products, in manufacturing and in the final product. For example: In the manufacture of electronic components arsine is used, one chemical agent with extremely high respiratory toxicity. This component can be reduced using a Point-of-use (POU) that are relatively small and typically dedicated to a single element of the process. These systems can remove up to 99.99 % of the effluent gases[[salud y seguridad Guías sobre medio ambiente, 2007](#)]

- **Electronic waste.** Inappropriate elimination of our electronic components can lead to serious health problems due to lead, cadmium and beryllium as these may be contained in the electronic devices. Some 50 million TV sets or 300 million computers were thrown away in 2013. It is anticipated that there 65 million tons of electronic waste are upcoming in 2017 [[Álvaro Rojas, 2014](#)]. All these wastes are sent to illegal dumping of countries in Africa and then don't get back to be recycled. These countries do not have sufficient capacity to recycle electronics. Companies are interested in recycling due to: Legislation on waste prevention, the customer satisfaction in obtaining cost savings and reduced investments of the company. To avoid this problem, we include a recycling rate in our product. When the product purchased by the customer is damaged or obsolete, we repair the aquaponics systems and take care of the recycling of electronic components.[[María Azucena Vicente Molinaa Unai Tamayo Orbegoza, Julen Izaguirre Olaizola, 2012](#)]

- **Reduction of lead-free materials.** The Wisconsin Association for Environmental Education (WAE) establishes that certain components of some electronic products contain hazardous substances e.g. mercury or cadmium that are harmful to the environment if they are treated and disposed of improperly. Others contain valuable materials that can be profitable if they are recovered[[Pia Tanskanen, 2013](#)]. Therefore the rules will be applied following RoHS “without lead” by restricting the use of the following substances: lead, mercury, cadmium, chromium VI (also known as hexavalent chromium), Polybrominated Biphenyls (PBB), Polybrominated Diphenyl Ethers (PBDE). The BLUE ANGEL labelling of German origin guarantees that our electronic components are easily recycled and do not employ the use of hazardous substances in their products.

- **Establishing political and practices for extraction of minerals.** We avoid providing suppliers involved in deforestation and illegal logging.

- **Reduce energy consumption of our product.** Although our product isn't self-sufficient with renewable energy, we wish to save energy with our components. For example: The use of a “light LED” in our aquaponics systems reduce electricity consumption between 75.94 % and 84.93 % compared to incandescent or saving bulbs [[Yesid Ramos Y. Ulianov Hugo Andres Macias, 2012](#)]. We also got great energy savings with the use of power supply for Raspberry Pi with 12 V output and 1.5 A consumes less 18 W at ma output. Labels in our electronic components as Energy Star guarantee us great energy savings and reduced greenhouse gas emissions.

5.3 Economical

Sustainability is defined as the ability of the economic system to adapt to the natural environment.

Due to the fact that natural systems have this ability and the human economy is a subsystem of the natural economy of materials and energy, this may not be sustainable when it behaves as a natural system [Roberto Bermejo, 2005].

The company Wipro is one of the most sustainable according to Greenpeace. Their rules are based on the reduction of greenhouse gas (GHG) emissions and use of renewable energy (solar energy). Thus the client knows when buying this product which is manufactured sustainably. This is a benefit for the client and for the company [Greenpeace, 2012].

Although our product is being promoted in the world (Belgium has aquaponic systems in Milan Expo 2015) [Expo Milano 2015 Belgium, 2015], it is still not well known globally. This means that to use our product has to have an aquaponic in your home. This makes aquaponic system are more expensive in relation to the product that we intend to build (see our competitors' products as Osmobot, Smart Controller Aquaponics Garden, Sensaphone400 and Sensaphone800 or Open Aquarium).

For our product was the most economical possible, we strive to ensure that our system: food security, sustainable decision-making and promote the success of our customers. Not all of our components (software and hardware environment) are Portuguese, however be manufactured 100 % in Portugal so we encourage job creation in the country. Reducing the electricity bill and water is also very important for the production of plants and fish from our aquaponic system.

So our system has a sensor that measures the water level. If the water level drops, the water level in the tank will increase; the same goes for the heater, this will only be activated when the water temperature does not correspond to the optimum conditions. Tank light is a LED light and it saves energy. Feeders are scheduled to throw food at times less energy costs and ultimately our food system is low consumption. Therefore we try our aquaponics systems is affordable for the customer and environmentally sustainable.

5.4 Social

Social sustainability can be described as a progression whereby the will to improve better living conditions is reflecting the aggregate actions of those involved. Human development based on social health, equity and democratic society is an essential path to socially sustainable companies [M. C. King V. Dujon J. Dillard, 2008].

5.4.1 User

People these days are always attainable by their use of smartphones, tablets and other devices. The monitoring of the aquaponic system from distance would fit perfectly in the current lifestyle. As a result of the app being web based, it's possible for the client to control the aquaponic system from a tablet, a smartphone or a computer. One of these devices is most likely taken by the user everywhere they go.

The aquaponic system is giving more pleasure because the user has the possibility to control it wherever and whenever. Time saving is the main advantage in this case. It is providing the user with more time for family, hobbies, work and other activities. Even business trips or travelling are not causing a problem. The timesaving is leading to the persuasion of people who want to get an aquaponic system but are in doubt of being able to maintain it because of the time they have to spend on it.

A free user-friendly customer service is provided for every client. The service is available 24 hours a day because the client can have crucial problems with the aquaponic system that could harm the fish.

5.4.2 Company

The product is produced in a green building that is environmentally compatible and serves as a safe work environment. The sources of the materials that are being used don't have any history of abusing the environment. Creating a workspace in this manner increases the safety feeling from the employees. A safe building is not enough to create a safe work environment, the people who are in it have to be aware of the safety rules apply them. Safety trainings are organized every year and everyone who works in the building has to attend to these.

The work schedules are partly chosen by the employees, which give them the opportunity to divide their time usefully. This is giving the employees more control over the time they work and the time they can spend with family our hobbies. The company is offering a fair wage, which is also an inducement factor.

Evaluations with the employees are held every six weeks. This is a great opportunity for the company to receive feedback from the employees and for the employees it is a great chance to give feedback or input. The company is prepared to listen to the input of the employee, because it is always interesting to see things from another angle. Plus the employees are a very valuable component of the company. It is one of the goals of the company to insure that all employees are treated in a respectful manner and are feeling comfortable. If these factors are fulfilled the employees will put effort in their work and enjoy it.

5.5 Life Cycle Analysis

Life cycle is a tool for the systematic evaluation of the environmental aspects of a product or service system through all stages of their life cycle. With this tool we intend to evaluate the environmental impact of our product and create a sustainable product with: the reduction in use of toxic materials, recyclability, use of natural resources and the long duration of our product.

The life cycle of electronic components has decreased significantly, generating a large volume of waste (e-waste). These residues can cause serious environmental problems due to the toxicity of its components. Therefore, it is necessary to use the life cycle in our product[Mariana Villanueva Bringas,Juan Gaytán Iniestra,Marco García Vargas Pilar arroyo López, 2012].

It can be separated into the following parts: extraction of raw materials or acquisition; manufacturing and processing; distribution and transportation; use and reuse; recycling and disposal.

Extraction of raw materials or Acquisition.

We do not manufacture all the pieces to form our aquaponic systems. Therefore we will have to contact different suppliers. To opt for a component or another we have relied on price, location, impact on nature, weight and material properties. Although we offer an innovative product in the market there are several competitors, so we have taken into account the price of the components. Almost all of our components come from a company. Therefore, saving on shipping in the same packaging is much higher. Some of our components aren't Portuguese, so they have to be transported; in the case of the heater, whose country of origin is German. However, this product

complies with RoHS certificate of conformity so we don't hesitate to choose it. Finally we have sought materials that are of high quality, environmentally responsible, with a light weight for greater mobility and convenience in the product.

Manufacturing and Processing

Aquaponic systems is a product manufacturing- intensive product. This means you have many electronic components, so, we must ensure that all these have a long durability. Regarding the manufacturing process, we are ourselves that we have set up our aquaponic system.

Distribution and Transportation

Our goal is to bring consumer aquaponic system properly, for that we use are two important elements: the distribution channel (reflecting the life of the product so that its environmental assessment will give a true picture of the economic benefits of product) and the reverse channel (which includes the collection of waste materials at the end of the life of the aquaponic system). It is in the latter where the role of recycling marketing plays a very important role, which will favour the transformation of organic materials into energy or other organic materials.

Use and refuse

To use our aquaponic systems is necessary to have electricity. As we know, getting electricity from renewable energy is sustainable but would increase the cost of our product, so we decided don't include it. To reduce energy use our product includes a LED light and the power supply uses less energy power supply for Raspberry Pi With 12 V output and 1.5 A. Thus that max power our computing components will use is 18 W at any given moment. If considered a laptop uses a 60 W power supply, 18 W is considerably low. However we meticulously careful choose our components so therefore consumption is smaller and its performance resembles the ideal.

Recycling

If some components of our aquaponic systems stop working, we can be responsible for repairing the component or we change the component, so that we ensure that the user does not make a bad use of this component and we take care of recycling.

5.6 Conclusion

Every day more people use electronics. The electronics may improve our quality of life but their manufacturing, use and disposal is harmful to the environment. Gradually customers know that unless we act now, it will have serious consequences for our future. So clients demand electronic products. We tried with these measures that our aquaponic system is sustainable with the environment. Therefore, if our aquaponic system is sustainable, this will lead to savings for us and also for the client. To achieve this goal we need to establish ethical and professional standards. These will be discussed in the next chapter.

6. Ethical and Deontological Concerns

6.1 Introduction

The importance of ethics in all aspects of life cannot be neglected. It influences human decisions, points of view and behaviour. Because of that, it is essential to consider all concerns that might arise during project design and production phases. For example: are the aquaponic systems new 'chicken farms'? Meaning are the animals being grown to exactly fit human needs with minimal necessary comfort given. That concern is being overcome with ensuring that the prototype will allow to give the fish the conditions closest to natural concerning nutrition as well as comfort. Moreover the ethics is the complex issue connecting different approaches and fields. In this paragraph the doubts connected with project design, development and production will be discussed as well as the marketing strategy ethics and the system impact on the final customer. The intellectual property and liability concerning the project will be also covered. The aquaponic system control is an even more difficult and complex task for designing due to having to deal with two different kinds of living organisms – plants and fish, which leads to the necessity to consider influence on both of the types as well as codependences between them.

6.2 Engineering Ethics

Engineering ethics is the study of moral issues and decisions faced by individuals and organizations involved in engineering, also considered as a study of issues related to moral conduct, character, ideals and relations of peoples and organizations involved in technology development.

Our duties as engineers:

“We must promote the prestige of our profession always acting in good faith, loyalty and impartiality individually or collectively” and “refuse work that is not up to our areas of study” [[Ordem dos Engenheiros, 2013](#)]. Not all members of the team are specialists in electronic engineering from which to develop our project we will need to contact with a specialist in electronics to guide us.

“We have the obligation to give our opinion on the development of aquaponic system with an objective and impartial manner” [[Carlos Carapeto, Fátima Fonseca, 2012](#)]. Each opinion of the group members is valid for be discussed by the rest.

As engineers we are aware that we have to defend natural resources and the environment [[unknown, 2012](#)]. So we must find electronic components with high durability, environmentally sustainable and then commit to recycle the components at the end of its useful life.

Ensuring the safety the project and our future customers, we must avail ourselves safety standards as EU Machinery Directive (MD), Low Voltage EU Directive (LVD) and Restriction of the Use of Certain Hazardous Substances (RoHS).

Find the best technical solutions, considering the economy, production quality or design works, conduct or organize.

Advertising:

We can't use advertising as a benefit. We must exercise utmost sobriety in the professional ads we do. We will give all the details of our aquaponic system with its advantages and disadvantages both in our brochures and on the internet.

Mutual duty between team members:

Objectively appreciate the work of our group members, contributing to our recognition and career advancement.

Oppose any unfair competition between us.

Provide ourselves all possible assistance for the development of our project.

No engineer of our group will be refused, only if replacement is required and giving the engineer the necessary satisfaction.

It is very important to keep all in original investigations for the proper development of the project and that will be recognized both socially and professionally.

6.3 Sales and Marketing Ethics

Ethical problems arise in marketing activities. Many companies today do not meet the ethical standards in their actions because they are more interested in increasing the profits than the guaranty of their products. Violating the code of ethics in marketing can bring benefits quickly, but afterwards will cause a deterioration in the business, a loss of credibility and customer mistrust. Therefore we can summarize that: if the product has higher quality, therefore the productivity for the company will be increased and the costs will be reduced.

For us, the communication with the customer is the most important fact and that is why we seek to be transparent, understandable and attractive. Only thus we get the trust and customer welfare and thus get a mutual benefit. The customer will be satisfied with the quality of the product, our benefits will be increased and the satisfaction of having done a good job. Therefore we use advertising as a tool of communication with the customer to inform clearly, without comparing or disparage other products on the market (OsmoBot, Sensaphone, Open Aquarium). Definitely we want to show the results that can be obtained with its use and technical details of the device. The customer could freely choose if the product meets the expectations he has set. We don't want to create false advertising, we want to move in the world of advertising rationally and with good manners.

As mentioned in the marketing plan, the convenience of controlling your aquaponic system on your computer from anywhere, the demand for organic food, saving on water consumption in the production process, as well as other environmental factors make customers more interested in systems like the aquaponic system. We want to reach these customers who have an aquaponic system at home, to further facilitate their daily lives. To attract new customers, we explained the advantages of having an aquaponic system at home and when they decide to purchase it, we can offer these potential customers our product.

6.4 Academic Ethics

When we formed the group, we thought we should assume a set of guidelines because some members of the team don't have knowledge of electronics. For this reason we decided it was important to establish academic expectations for the group. This ensures the members who have more knowledge aren't overworked.

In academic ethics we consider the definition of plagiarism. "Plagiarism is when a person takes the ideas or words of another person and used in any oral or written work without giving credit to the

person whose ideas or words are being used.” [C. Park, 2003] Therefore, every time we collect information from the internet, books or articles and make use of them in our work we must reflect the place from which we take these information.

6.4.1 Another Ethics obligation

6.4.1.1 Obligations as a group

Obligations as a group: As a group we should have a relationship of mutual respect, understanding, kindness, solidarity, loyalty and cooperation. By establishing these premises we provide a good atmosphere in the team and therefore increase the motivation and enthusiasm for the job. Each group member has an assignment for the development of the aquaponic monitoring system, so each of us must do their work within time limits set by the team to help each other.

6.4.1.2 Obligations with teachers

We participate in all classes, maintaining a proper environment. Respect other students who want to attend and the teachers who are doing their jobs.

In the group meetings we enter well prepared for any doubts that may arise. We complete our given tasks before deadlines, so the advisors can criticize any faults we have in our projects. This regards to deadlines set by the EPS supervisors as well as team internal deadlines. Due to this we can improve it and consider all the suggestions. This method is better than simply copying the work of others. We have also managed a website to allow everyone to get information about the product and about us. To carry out our work we are using open source software to avoid problems with licensed programs.

6.5 Environmental Ethics

Environmental ethics is a part of philosophy that deals with the study of the relationship between humans and the environment. It worries that men do not conflict with the development and evolution of natural beings.

At company level environmental ethics require responsibilities for the care of our natural environment and therefore we must seek the welfare between society and nature so humans can develop in an environment free from pollution. Environmental problems and product life cycle are linked so we try to minimize the environmental impact of the final product.

To meet the environment we must meet the guidelines set out the EU regarding waste management and electronic equipment (WEEE) which requires collecting electronic devices that are no longer used. So we try our product to meet the following:

1. Be free from harmful materials such as lead mercury, lead, or cadmium which comply with European RoHS
2. In case of breakage of any component of our product, we will take care of dismantling and repair parts to try to reuse or recycle if that could not be reused
3. Ensuring that the product materials have long durability and quality

4. Produce energy savings both in its manufacture and subsequent use.

6.6 Liability

Today customers complain because they disburse an amount of money in an electronic and probably, a few years later this product becomes obsolete or it will be broken. So we have to consider on the responsibility we have with our customers, supervisors and law [Alex Fernandez Muerza, 2012]. The errors shouldn't exist in our aquaponic system and get it we will rely on the following:

We have to comply with the law of intellectual property related to our product. We have to consider: copyrights, trademarks, and not to infringe existing patents none of these. Therefore, we can't get into the intellectual property of our competitors (Osmo Systems, Kijani Grows, Kijani Grows, Cooking Hacks) and company have created a logo and a website so they also make a difference with our competitors.

- Dissatisfied customers: when complaints are reasonable we will be the first to meet customer needs. We comply with the legendary motto "the customer is always right". So this does not happen we will have to establish warranty terms, so that if failure by our fault (e.g. bad installation, poor quality of components) will be repaired as quickly as possible.
- Safety instructions, "user manual": the client must know what the product that he purchased is and its operation. We must also warn of the potential risks could have on your health if you use the aquaponic system inappropriately.

To make a sustainable product, and within the framework of legality, use the applicable regulations of the EU, as it instead of using our product. They will be used the following standards:

- LVD: Low Voltage EU Directive
- MD: EU Machinery Directive
- RoHS: Restriction of Hazardous Substances
- WEEE Directive: Waste Electrical and Electronic Equipment Directive

6.7 Conclusion

In conclusion to this chapter, we have established the ethical standards to develop our product. As engineers we have obligations to fulfil under the code of ethics established in Portugal. In the area of marketing we establish our advertising must be clear, without belittling the other manufacturers. We seek higher product quality for increased productivity and lower costs. The relationship as a group should be optimal and the relationship with our supervisors. As for environmental ethics we should make a product that respects the environment by reducing the environmental impact. And finally we cannot forget our manufacturing obeying both European and international standards. Now that we have established our rules of ethics group, we can start with the design and components which will compose our aquaponic system. These are points that we will discuss in the next chapter.

7. Project Development

7.1 Introduction

As previously stated an aquaponic system is a habitat where fish and plants coexist. Buying an aquaponic system is easy, keeping it is a challenge for everybody. It requires time and involvement. Without human intervention an aquaponic system doesn't have a long life, but this changes with technology accessible for easy maintenance. The objective of our project is to deliver a product that can be installed on an existing aquaponic system which will be easy to control and monitor.

7.1.1 Software Overview

The software encompasses three components; a website, an Arduino sketch, and a python program. The website allows the user to view and send information to a database. The Arduino sketch runs on an Arduino Uno. The sketch reads values from sensors, and also controls stepper motor, and multiple relays.

Website

The website is the only interface with the user. The website serves as a hub to send and receive information about the system. When the user logs into the website they can view information from the tank sensors on the check status page. The user can then access a page to send changes to the system. There is an additional page to view a live video feed of the fish tank. The sitemap is displayed in Figure 12.

The functionality of website is written in PHP. This language allows the website to communicate with the data server. The data server in other words is a MySQL database. The check status page reads the displayed information form the data server via the TankStatus table. The change status page allows the user to submit changes to the data server. This sends the changes to ChangePack table in the data server.

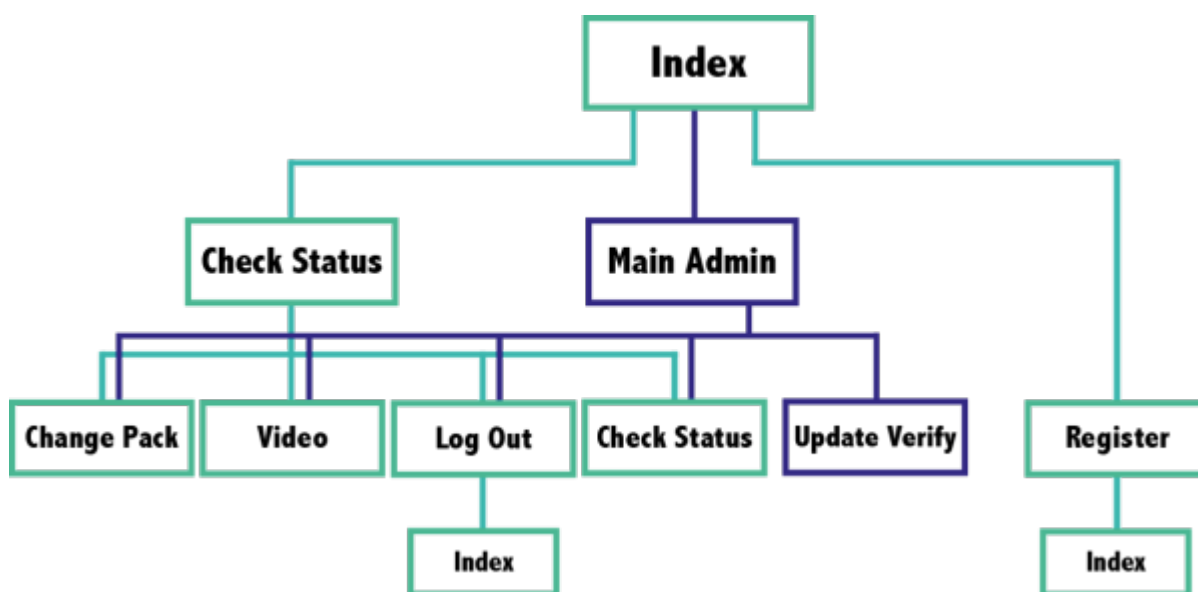
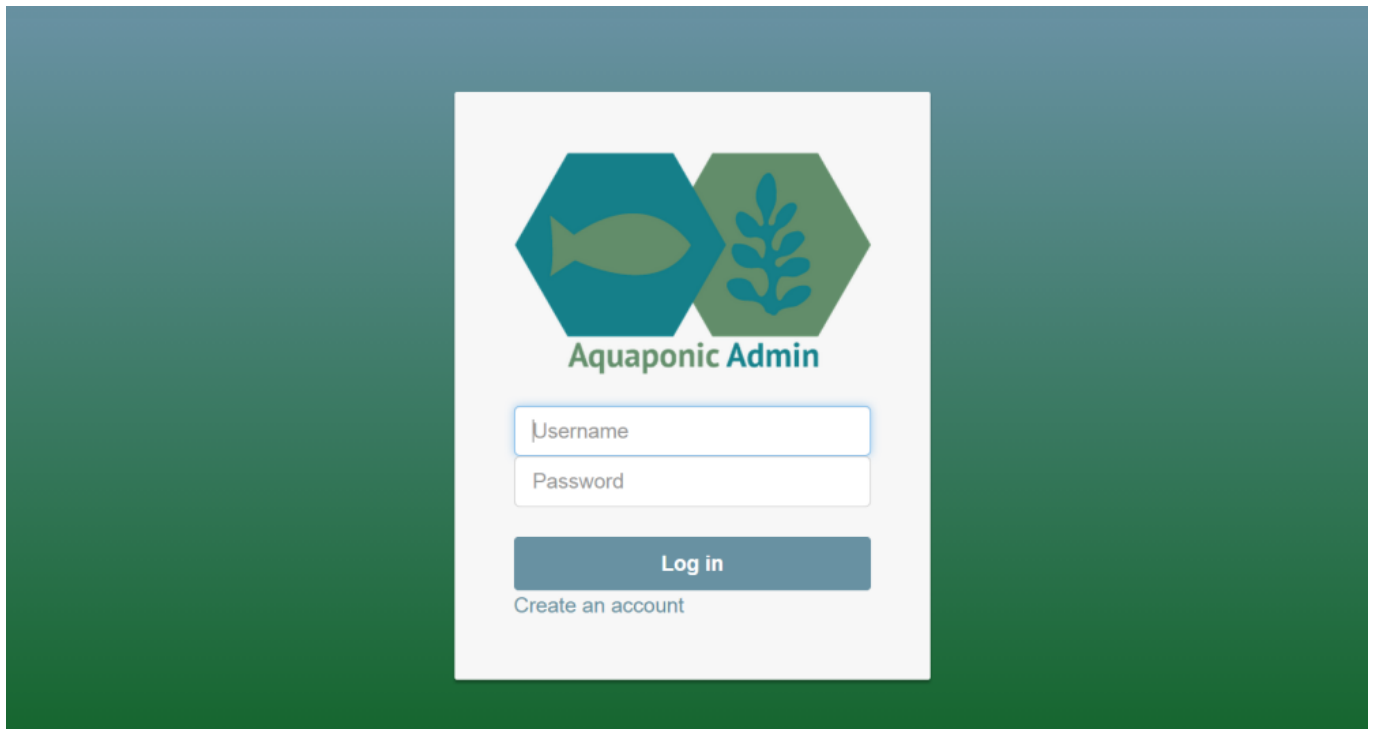

Figure 12: Sitemap

The website [Aquaponic Admin, 2015] can be accessed from everywhere on any platform that supports web navigation and for accessing all the subpages you will need an account. To register an account, you need a verification code by GRAQ. Otherwise you can only see the home page which is shown in Figure 13.



ISEP EPS 2015 Team 4: ALVD - SVD - KVT - RVB - JRR - FJR

Figure 13: Home page of Aquaponic Admin

Raspberry Pi

The Raspberry Pi enables the capability for the user to send information to the Arduino which monitors and controls the physical components. To achieve this functionality a program is on the Raspberry Pi. The program is written in Python and runs continuously on a Linux operating system. This program has three simple functions; Setup, TankStatus, and ChangePack.

The Setup function insures that everything is working properly. The function confirms that there is an internet connection, establishes a connection to the data server, and confirms that the Arduino is connected via serial. If something is not working it reruns to the beginning to recheck. If there is still an error it tries to fix the error. If it cannot fix a critical error the system reboots. If the error is not critical it will alter the user and skip the protocol causing the error. Once the Setup function is complete, The TankStatus function begins. The TankStatus functions calls for each sensor to return information one at a time. That information is saved to an array which is sent to the data server in the TankStatus table. Once the TankStatus function is complete the ChangePack function begins. The ChangePack reads the most recent input from the data server in the ChangePack table. These values are then sent to the Arduino.

Arduino

The sketch for the Arduino was written in Arduino interface which processes a .ino file. The Arduino interface C and C++ syntax. The Arduino sketch is broken into multiple functions. The sensor function waits for a character from the Raspberry Pi via the serial port. Once the charter is received a sensor is returned via the serial port. When the Pi sends a 1 the Arduino returns the reading from the temperature sensor. When the Pi sends a 2 the Arduino returns the reading from the depth sensor. When the Pi sends a 3 the Arduino returns the reading from the flow sensor. When the Pi sends a 4 the Arduino returns the reading from the feeder sensor.

The data transfer diagram of these connections is illustrated in Figure 14

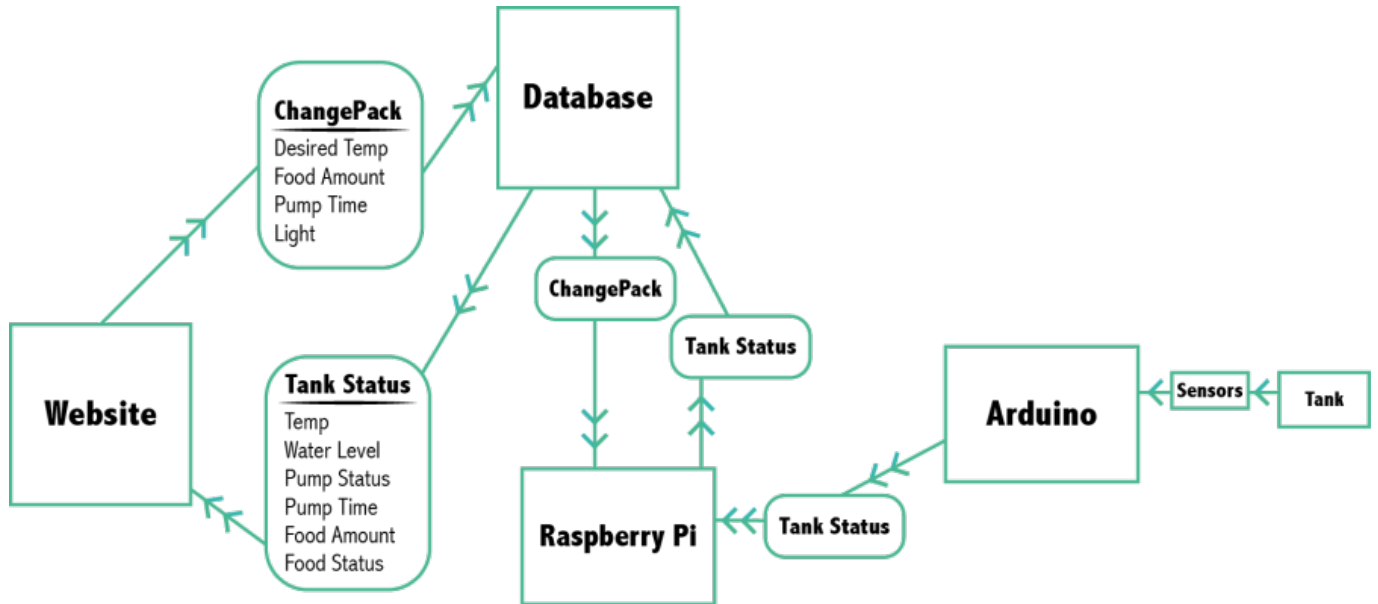

Figure 14: Data Transfer Diagram

7.1.2 Hardware Overview

Our product uses several components to achieve the desired functionalities. All of the components are described in great detail in the following section 7.3 Components. This section will discuss the key components and their role in our product.

7.2 Architecture

Hardware Model 1

The diagram for our original design is shown below in Figure 15. This version uses independent power supplies for the Raspberry Pi, Arduino, heater, water pump, feeder and light. Each power source is wired in parallel to run from one electrical outlet. In addition the pump, heater, feeder and light are connected through a relay, which is controlled by the output pins of the Arduino. The Arduino is connected to a USB port on the Raspberry Pi to allow for the serial communication described above in the software section. The USB webcam is also connected to one of the USB ports of the Raspberry Pi to allow for video streaming.

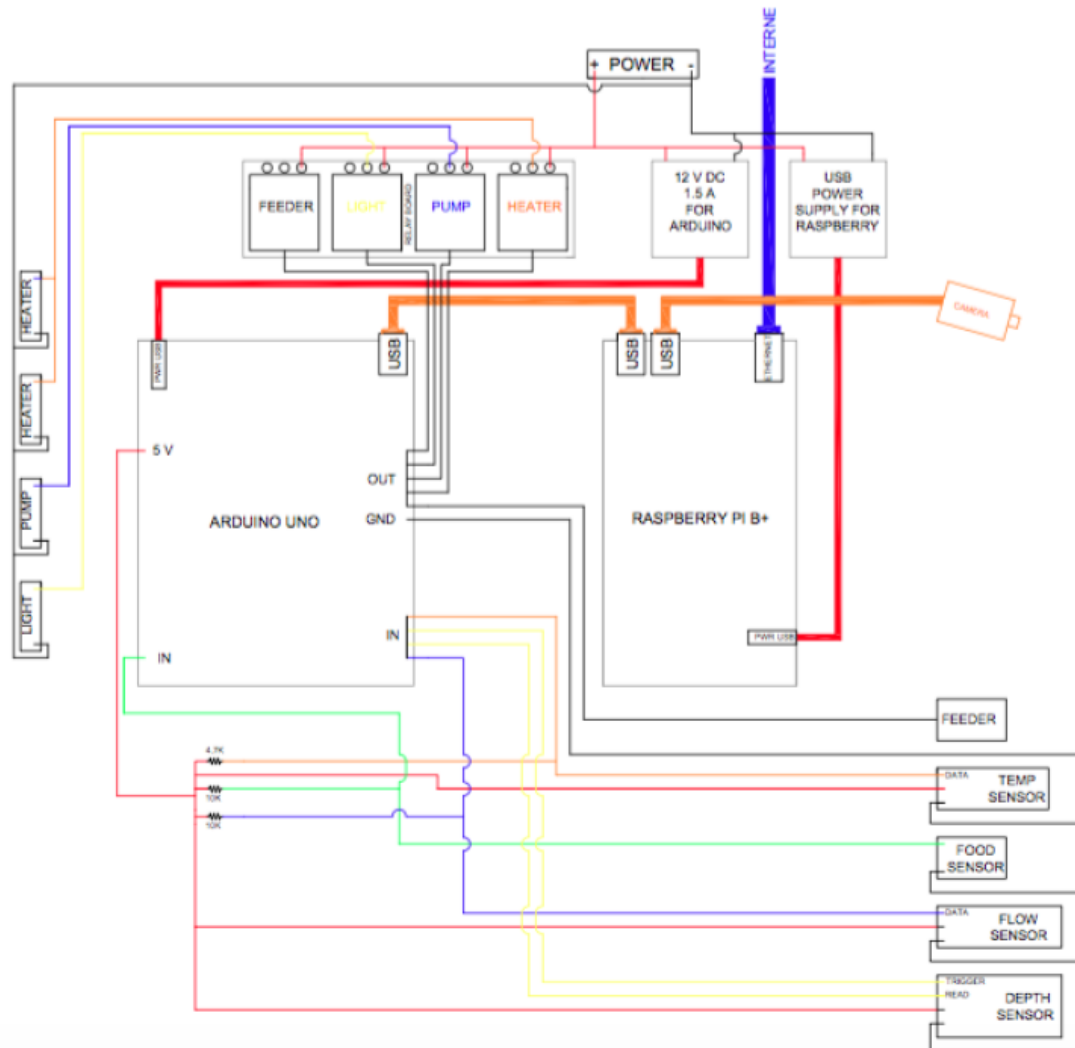

Figure 15: Schematic 1

Software Model 1

In this section we discuss the early design of the software modules. Each module has a description of the desired functionality. This structure was intended to achieve the original specification of the client.

Web App

The website uses several PHP scripts, some structured in HTML. home.php - Despite the file extension this file has only HTML commands. This is the home or index page. From this page the user can log in, or register for an account. The file takes input for username and password, with a button to submit the request. This button sends the username and password to Login.php. There is also a link to register for an account. This link opens register.php.

Login.php - This is a pure PHP script that checks the credentials of user. The entire script is wrapped in a session to prevent access to pages without logging in and to allow independent sessions for multiple users on the website. Once the session begins the MySQL database connection is established and a query is performed to check if the username and password are valid. The registration process uses md5 encryption, so the password entered by the user is translated to the md5 equivalent. At this point the code will check that; a username and password is entered, the username is assigned, and the password matches the specified username. If not the appropriate error message is returned. If the username and password match; the user is sent to Main.php.

Main.php – main.php is used as a placeholder or home screen for once the user logs in. From this page the user can access ChangeStatus.php, CheckStatus.php, Videopage.php, and Logout.php via displayed links. This page is also session dependent. This page uses HTML for styling and PHP for session handling.

mainAdmin.php – This page is the same Main.php other than there is a link to UpdateVerify.php. The mainAdmin.php can only be accessed by the administrator, which is defined as the first registered user. This page is also session dependent. This helps insure that only a user logged in as the administrator can access UpdateVerify.php.

UpdateVerify.php – This page allows the administrator to change the verification code needed to register as a new user. The code also reconfirms that the user session has administrator username and password. The change of the verification code is then saved to the administrator data in the database.

register.php – If page uses HTML to take in user input for variables : `FirstName`, `LastName`, `Email`, `UserName`, `Password`, and `Verify`. The PHP portion confirms that all fields have been entered. If not the appropriate error message is returned. The variable `UserName` is checked in the base to insure it is not already taken. The variable `Verify` is compared with `Verify` from the administrator. The `Verify` must match to register.

ChangeStatus.php – This page continues the session from Login.php, and must be active to access the page. If not the user is asked to log in. Once the session is verified, a query to the database is used to retrieve the saved setting. The results from the query displayed on the page. The retrieved variables are `Light`, `PumpTime`, `Food`, and `SetTemp`. `Light` return 0 if the light is set to off and 1 if the light is set to on. `PumpTime` is the number of minutes the pump is on per hour. `Food` is the amount of food to feed the fish per day. `SetTemp` is the temperature the user wants the tank to be at. All of these variables can be changed using the corresponding buttons. Once the variables are set the send button must be pressed to commit the changes to the database in.

.CheckStatus.php - This page continues the session from Login.php, and must be active to access the page. If not the user is asked to log in. Once the session is verified, a query to the database is used to retrieve the most recent reading from the sensors. The results from the query are then displayed on the page.

Videopage.php – This page will stream video from the tank. Logout.php - The page will terminate the session and return the user to home.php. This page uses HTML for styling and PHP for session handling.

Linux App: AquaDemo.py

Libraries:

- MySQLdb – to access database
- Sys - provides access to basic variables
- Serial – to read and send data through the serial port
- Sched – to schedule task
- Datetime – to allow the program to know the computers date and time
- Time - allows the program to use time dependent features
- Threading – allows the use of threads to run timers in parallel

Functions:

- Main - this function calls multiple functions to perform specific task.
- ChangePack - cancels all pending times, performs a query to get the most recent row from the ChangePack in the database.
- The results from the query are saved to an array. The array is compared with the previous ChangePack query. If there is a change the array is sent to the serial port.
- TankInfo - Uses nested decision making to ask the serial port for the following one by one; TankTemp, Camera, WaterLevel, PumpStatus, PumpTime, FoodAmount, and FoodStatus. If it does not receive an answer the function will ask the serial again. If there is still no answer the user will be alerted via email that there is a problem.

There are also independent functions to turn on and off the; pump, feeder, and light. These functions are time dependent and actuate based on the setting of the user. Each of these functions operates in the same way. When the function is called the following commands happen in the following order. Check if the serial port is busy. If the port is open it is busy. If the port is not busy it is closed. If the port is not busy open the port. Write the corresponding number to the serial port. If the serial port is busy the function will wait three seconds and retry the function. Once the function is complete the function will close the serial port and sleep for one second before returning to the main function. The serial port communication protocol established in the Serial python library mentioned above. To keep communication between the Raspberry Pi and Arduino the Linux App sends a single character to the Arduino 1, 2, 3, 4, 5, 6, 7, 8, 9, a, or b. The Arduino then responds with a designated action.

TankInfo is considered to be the primary function and is on a set timer thread to run every 15 minutes. Since it is a primary function it has provisions to stop any scheduled function. These provisions do not include the Camera function. Once the camera stream begins it does not need access to the database to run, nor does it need access to the main serial port. This means that all other functions will not interfere with the camera stream, as long as there is available bandwidth.

Arduino Sketch

The Arduino runs a continuous sketch consisting of several functions. Their tasks are to read values from the sensors and control devices connected to the microcontroller. The main idea behind the code was to turn the connected devices only when requested by Raspberry Pi. **Used libraries:**

- One Wire - allows using waterproof temperature sensor DS18B20, is applied to detect the sensor and create monitoring instance.
- Dallas Temperature - used along with One Wire, provides the drivers for the sensor and interpretation for input coming from it.
- Stepper - allows the control of stepper motor movement e.g. number and speed of rotations.
- IRremote - library operating infrared shooting sensor and allowing to create modulated infrared signal emitted from the connected diode.

The code structure is presented below.

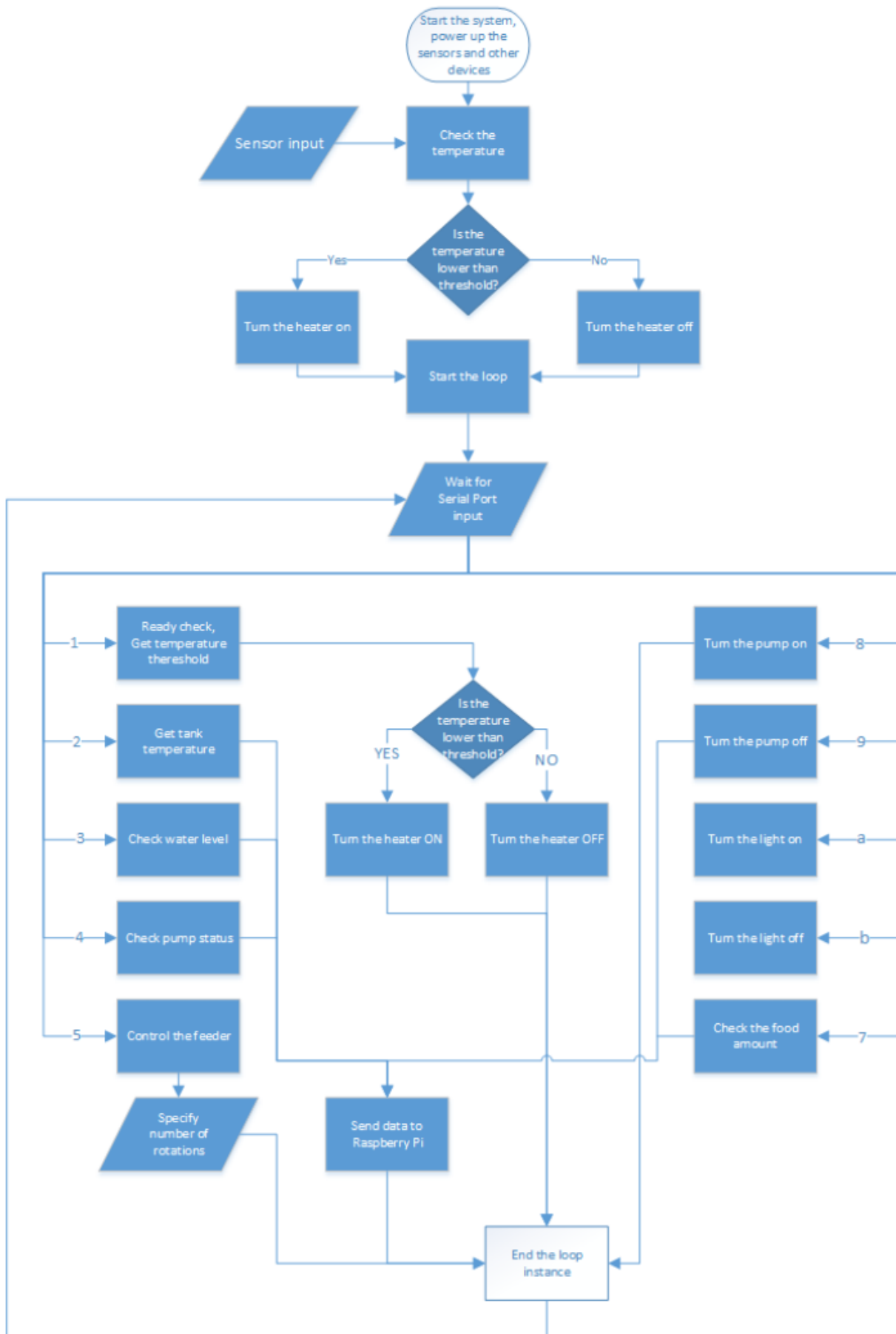

Figure 16: Flow chart for Arduino code

The initial setup for Arduino consists of defining the pin status and first temperature request in order to turn the heater on automatically if the water is too cold.

Further code flow is controlled by Raspberry Pi *i.e.* that the microcontroller only responds to the requests sent through the serial port. Firstly there is a ready check performed, then the several values are obtained from sensors, and sent back to Raspberry Pi. afterwards, the user input from website is applied *i.e.* the settings for feeder, pump, lamp and heater are uploaded and applied. The code runs in continuous loop.

7.3 Components

In this subchapter we speak how we choose our components and confirm our decision.

For selecting the products we have three important criteria to follow. First and the most important is our budget of 250 €, the second criteria is to use only three suppliers of products because we will limit shipping charges and the last criteria is to use only Restriction of Hazardous Substances (RoHS). In order to achieve monitoring and control a list of necessary components and comparison tables were created.

- BeagleBoard

Beagle boards are a solution instead of using Arduino and Raspberry. In the next table, we compare the boards and we will decide what the best for our budget is.

The BeagleBoards are a low-cost, fan-less single-board computer based on low-power Texas Instruments processors featuring the Acorn Reduced Instruction Set Computing (RISC) Machine (ARM) Cortex-A series core with all of the expandability of today's desktop machines, but without the bulk, expense or noise. In Table 26 we compare our proposed products.

Table 26: Comparison table

BeagleBoard Models	BeagleBone Black	BeagleBone	BeagleBoard-xM	BeagleBoard
CPU model	Cortex-A8			
CPU Frequency [MHz]	1000	720	1000	720
GPU [MHz]	PowerVR SGX530			
USB Connection	1x USB, 1x mini-USB	1x USB, 1x mini-USB	4x USB, 1x mini-USB	1x USB, 1x mini-USB
Onboard storage	4 GB	No	No	256 MB
GPIO [pins]	65			
Price [€]	61.56	74.54	166.60	124.95

- Raspberry Pi model B+

The Raspberry Pi is a series of credit card-sized single-board computers developed in the UK by the Raspberry Pi Foundation with the intention of promoting the teaching of basic computer science in schools.

Raspberry is a single-board computer and will be used to send and receive data over the internet, to control an Arduino microcontroller and a webcam for video surveillance. We choose this model

because we need: 4 USB connections (one for webcam, one for communication with Arduino, one for the mouse and keyboard and another one for USB Wi-Fi adapter) and wired internet communication. In Table 27 we compare our proposed products.

Table 27: Comparison table

Raspberry	Model A	Model A+	Model B	Model B+	Generation 2 Model B
Memory (SDRAM)	256 MB (shared with GPU)		512 MB (shared with GPU)		1 GB (shared with GPU)
USB 2.0 ports	1		2 (via the on-board 3-port USB hub)	4 (via the on-board 5-port USB hub)	
On-board storage	SD / MMC / SDIO card slot (3.3 V with card power only)	MicroSD slot	SD / MMC / SDIO card slot	MicroSD slot	
on-board network	none		10/100 Mbit/s Ethernet		
Price [€]	19.07		33.20	31.95	44.20

To decide between a component or another, we have chosen the model of Raspberry Pi over the BeagleBone model. For this purpose we have made a comparison shown in Table 28.

Table 28: Comparison table

Characteristic	Raspberry Pi B+	BeagleBone Black
Dimensions	12,2 x 2,4 x 7,6 cm	8,6 x 5,3 x 1,5 cm
Weight	50 g	39,68 g
Chip	broadcom bcm2835 soc	am3358/9
CPU	700 MHz	ARM cortex- a8 1 GHz
Memory	512 MB	512 MB
Operating Systems	Angstrom, Ubuntu, Android, others...	Raspbian, Ubuntu, android, archlinux, others...
Ethernet	10/100 based Ethernet socket	10/100, RJ 45
Power supply	micro USB socket 5 V,2	micro USB 5 V
Video output	HMDI	HMDI
Audio output	HMDI	HMDI
USB	4 x USB 2.0 connector	1 x USB 2.0 connector
GPIO	40 pins	46 pins
Internal Storage	SD	2 GB

The reasons why we decided Raspberry Pi B + against BeagleBone Black are:

- USB: Raspberry Pi B+ has 4 x USB 2.0 connectors vs 1 x USB 2.0 connector from BeagleBone Black. For our aquaponic system we need to connect with Arduino, camera and wireless Ethernet so we need more than one USB.
- Community: Raspberry Pi has sold over one million units and it has more coverage in the medial communication and global exposure. Beagle Bone Black has a growing community but it's not enough. Raspberry Pi production generates 13 times more productivity than BeagleBone Black.
- As for our aquaponic system BeagleBone Black would be as valid as Raspberry Pi B+ but the price was decisive. As we can see from the chart the price of Raspberry Pi B+ is 31.95 € compared to 61.56 € Beagle Bone Black. As our product has to have a lower price than 250 € we decided that it was a

good choice to select the Raspberry Pi B+.

- Arduino Uno

Arduino is an open-source computer hardware and software company, project and user community that designs and manufactures kits for building digital devices and interactive objects that can sense and control the physical world.

Arduino is a single-board microcontroller used for receiving data from sensors and controlling: the pump, heaters, temperature sensor, depth sensor, infrared sensor, light and a small motor for the feeder. Arduino is connected with Raspberry Pi through an USB cable. In Table 29 we compare our proposed products.

Table 29: Comparison table

Arduino Model	Uno	Leonardo	Mini Pro	Nano	Due
CPU model	ATmega328P	Atmega32U4	ATmega168 or ATmega328	ATmega328 or ATmega168	ATSAM3X8E
CPU Frequency [MHz]	16	16	8 or 16	16	84
USB Connection	Yes	Yes	No	Yes	Yes
Number of digital I/O [pins]	14	20	14	14	54
Number of digital I/O [pins]	6	7	6	6	12
Number of analog input [pins]	6	12	6	8	12

To decide between a component and another, we have chosen the model of Arduino Uno over the TI LaunchPad model. For this purpose we have made a comparison shown in Table 30.

Table 30: Comparison table

Characteristic	Arduino Uno	TI LaunchPad MSP430
Data Bus	16 bit	8 bit
Speed	16 MHz	16 MHz
Storage	16 kB	32 kB
RAM	512 B	2 kB
Memory	512 MB	512 MB
Digital I/O	8 channels	14 channels
Analog I/O	8 channels	6 channels

We have chosen Arduino Uno because:

- Arduino has massive community support. This is not to be under-estimated.
- In Arduino there is no limit in a future expansion because the boards called 'shields' can be stacked on top of the board to add features, in the MSP430 that's not possible.
- Arduino one can run at 5 V or 3.3 V (or anywhere between 1.8 V and 5 V if you change oscillators) while The MSP430 caps out at 3.6 V.
- The Arduino has 20 I/O pins, while the MSP430 has 16. It might not seem like a huge difference, but in some projects where 18 of those pins are needed you might need to buy a pin expander to gain 8 more.

After we analysed the possibilities, instead of a BeagleBoard and TI LaunchPad, we chose Raspberry B+ and Arduino Uno. Another reason why we prefer Arduino and Raspberry is because we have one

team member with experience in programming and controlling an Arduino. The total price of this combo is visible in our budget list and it is 54.85 €.

- Memory card 16 GB

The role of the card is to run the Linux platform on Raspberry Pi and store data. Requirements for Raspberry Model B+ Linux platform is a minimum of 8 GB, but we need to guarantee 16 GB to back up our programs and feature updates for Linux platform. Another characteristic for our card is the class (class is made from 2-10) and if the class number has the highest number that means high speed. The speed is important for fluid movement of the Linux platform. In Table 31 we compare our proposed products.

Table 31: Comparison table

	Kingston	Transcend	Lexar	Panasonic	Apacer
Class	10				
Price [€]	10.90	15.93	20.59	133.19	45.28

- Wi-Fi modules for Raspberry Pi

The decision to communicate with a Wi-Fi module is because we will use less cables to connect our monitoring system to the internet. The Wi-Fi modules are preferred if you don't have space for cables or access to internet plug. In Table 32 we compare our proposed products.

Table 32: Comparison table

Wi-Fi Modules	Pi Tin Clear	Wi-Fi USB Dongle	Miniature Wi-Fi Module 814	EW-7811Un nano USB Adapter	Wi-Fi module
Standards	IEEE802.11 b/g/n				
Price [€]	9.80	11.01	11.85	18.45	25.15

- Webcam

The webcam is just for the video surveillance. For webcam compatibility with Raspberry Pi we consult a website where a community published a compatibility list. In Table 33 we compare our proposed products taken from [eLinux, 2015].

Table 33: Comparison table

	Logitech C170	TRUST 17003	Logitech 210	300 k Pixel Mini Webcam
Compatibility	works fine without power hub, image/video quality is poor	unknown compatibility	works fine without powered hub	compatible with Raspbian
Price [€]	20.40	17.60	21.03	11.90

- Relay Module

Relays are electrically switches for: light, pump, heater and the motor of the feeder.

- Temperature sensor

The Temperature sensor is for monitoring the water temperature. In Table 34 we compare our proposed products.

Table 34: Comparison table

	DS18B20 Digital temperature sensor	Temperature Sensor with Steel Head	PT-100 Temperature Sensor	A86614 Interior Room Thermistor
Waterproof	Yes	No	No	Yes
Pre-made libraries for Arduino environment	Yes			
Price [€]	7.30	1.70	8.60	4.71

- Water Flow sensor

This sensor will tell us if the pump works. In Table 35 we compare our proposed products.

Table 35: Comparison table

	GEMS SENSORS 129661 FLOW SENSOR	Gems Sensors Liquid PP Flow Indicator	Liquid Flow Meter Model ADA-828	G1/2 Water Flow sensor Model PTR001426
Price [€]	185.92	58.96	12.24	11.19

- Depth sensor

The depth sensor is an ultrasound sensor which will tell the water level. In Table 36 we compare our proposed products.

Table 36: Comparison table

	Ultrasound Sensor HC-SR04	USB - ProxSonar - EZ (MB1414)	Maxbotix LV-EZ1
Voltage [V]	5	5	2.5-5
Maximum reading distance [cm]	400	318	645
Price [€]	12.24	59.80	30.96

- Water Pump

The device to pump the water from the fish tank to the growbed. It is provided by ISEP.

- Heater

The heater is for maintaining the right temperatures of the water. Our aquaponic system is build inside of an ISEP building and to heat our system we don't need too much power. Because we have a continuously working system we will never have too low temperature of water since it will work non-stop. Of course we did some calculations and we begin with the next formulas:

To be able to calculate how many watts we need for a heater we are forced to come with a scenario and the next formulas:

The next diagram represents our case of heat flow through the walls Figure 17 (section of water tank wall).

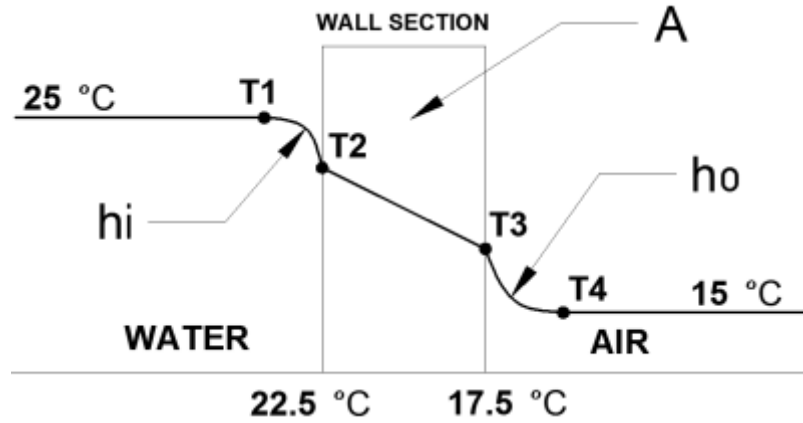

Figure 17: Heat flow through a wall

We will begin with the heat transfer rate Equation [\ref{eq:one}](#) [Christie J. Geankoplis, 1993]:

$$\dot{q} = U_0 \cdot A_0 \cdot \Delta T_{Total} \quad \text{\label{eq:one}}$$

- \dot{q} - Total energy loss in time
- U_0 - Overall outside heat-transfer coefficient
- A_0 - Outside area
- ΔT - Difference of temperature

Unknown coefficient is U_0 and to find U_0 we have the next Equation [\ref{eq:two}](#) [Christie J. Geankoplis, 1993]:

$$\frac{1}{U_0} = \frac{1}{h_i \cdot \frac{A_i}{A_o}} + \frac{x}{k_{PEHD} \cdot \frac{A_{Lm}}{A_o}} + \frac{1}{h_o} \quad \text{\label{eq:two}}$$

- U_0 - Heat-transfer coefficient
- x - Thickness of the material
- h_i - Heat-transfer coefficient inside
- h_o - Heat-transfer coefficient outside
- A_{Lm} - Logarithmic area of the film
- A_i - Inside area
- A_o - Outside area
- k_{PEHD} - Material Polyethylene High-Density

The first box displays the resistance of water and the second box displays the resistance of air.

To find h_i and h_o we will use a formula of natural convection heat transfer. The average natural convection heat transfer coefficient can be expressed by the following general Equation [\ref{eq:three}](#) [Christie J. Geankoplis, 1993].

$$N_{Nu} = \frac{h \cdot L}{k} = a \cdot \left(\frac{L^3 \cdot \rho \cdot g \cdot \beta \cdot \Delta T}{\mu^2} \cdot \frac{c_p \cdot \mu}{k} \right)^m \quad \text{\label{eq:three}}$$

- N_{Nu} - Nusselt number (dimensionless/adimensional number)
- h - Film coefficient of heat transfer
- L - Length [m]

k - Thermal conductivity [W/m·K]

a - Constant [Christie J. Geankoplis, 1993]

ρ - Density [kg/m³]

g - Gravitational acceleration 9.81 [m/s²]

β - Volumetric coefficient of expansion of the fluid (Equation \ref{eq:beta}) [1/K] [Christie J. Geankoplis, 1993]

ΔT - Positive temperature difference between the wall and bulk fluid in [K]

μ - Viscosity [kg/m·s]

c_p - Heat capacity [J/kg·K]

m - Constant [Christie J. Geankoplis, 1993]

N_{Pr} - The Prandtl number (dimensionless/adimensional number)

N_{Gr} - The Grashof number (dimensionless/adimensional number)

```
\begin{equation} \begin{aligned} \beta = & \frac{\rho_b - \rho}{\rho(T - T_b)} \quad \label{eq:beta} \\ \end{aligned} \end{equation}
```

The water tank is uncovered and in our case it is a cylinder with the following characteristics:

- Radius 0.77 m
- Height 0.55 m
- Cylinder thickness 0.005 m
- Material PEHD (polyethylene high-density)
- Top uncovered
- Bottom covered

For the calculation of heat loss we need a scenario in which conditions are a little bit exaggerated. The scenario is the following:

The water temperature is 25 °C and outside of the tank the air temperature is 15 °C.

The next calculations represent heat loss inside (h_i) and heat loss outside (h_o): We use the general formula for natural heat transfer Equation \ref{eq:ght}.

```
\begin{equation} \begin{aligned} \frac{h_i \cdot L \cdot k_{\text{water}}}{\rho^2 \cdot g \cdot \beta \cdot \Delta T \cdot \mu^2} &= a \cdot \left( \frac{L^3}{\rho^2 \cdot g \cdot \beta \cdot \Delta T \cdot \mu^2} \cdot \frac{c_p \cdot \mu}{k} \right)^m \\ \label{eq:ght} \end{aligned} \end{equation}
```

We take characteristics of water at our specific temperature from a website [The Engineering ToolBox, 2015] and we will interpolate where we need.

$L = 0.77$ m

ρ_{water} at 23.75 °C = 997.4 [kg/m³]

$\Delta T = 25 - 15 = 10$ [°C]

$c_{p \text{ water}}$ at 23.75 °C = 4181.5 [J/kg·K]

μ_{water} at 23.75 °C = $9.2 \cdot 10^{-4}$ [kg/m·s]

$k_{\text{water}} = 0.6004$ [W/m·K]

For β Equation \ref{eq:beta1} we calculate:

```
\begin{equation} \begin{aligned} \beta = & \frac{\rho_{25} - \rho_{22.5}}{\rho_{22.5}(T_{22.5} - T_{25})} = \beta = \frac{997.1 - 997.7}{997.7 \cdot (22.5 - 25)} = 2.4 \cdot 10^{-4} \text{ K}^{-1} \\ \label{eq:beta1} \end{aligned} \end{equation}
```

We use the general formula for natural heat transfer Equation \ref{eq:ght1} in order to know h_i .

$$\begin{aligned} \frac{h_i \cdot L}{k_{\text{water}}} &= a \cdot \left(\frac{0.77^3 \cdot 997.4^2 \cdot 9.81 \cdot 2.4 \cdot 10^{-4} \cdot 10 \cdot (9.2 \cdot 10^{-4})^2}{4181.5 \cdot 9.2 \cdot 10^{-4} \cdot 0.6004} \right)^m \\ \frac{h_i \cdot L}{k_{\text{water}}} &= a \cdot (8.1 \cdot 10^{10})^m \implies a = 0.13 \ ; \ m = \frac{1}{3} \\ \frac{h_i \cdot L}{k_{\text{water}}} &= 0.13 \cdot (8.1 \cdot 10^{10})^{\frac{1}{3}} \\ \frac{h_i \cdot 0.77}{0.6004} &= 0.13 \cdot (8.1 \cdot 10^{10})^{\frac{1}{3}} \\ h_i &= 438.648 \ \frac{\text{W}}{\text{m}^2 \cdot \text{K}} \end{aligned}$$

We take characteristics of air at our specific temperature from a website [\[The Engineering ToolBox, 2015\]](#) and we will interpolate where we need.

$$\begin{aligned} L &= 0.77 \text{ m} \\ \rho_{\text{air}} \text{ at } 16.75 \text{ }^\circ\text{C} &= 1.219 \text{ [kg/m}^3\text{]} \\ \Delta T &= 25 - 15 = 10 \text{ [}^\circ\text{C]} \\ c_{p, \text{air}} \text{ at } 16.75 \text{ }^\circ\text{C} &= 1004.5 \text{ [J/kg}\cdot\text{K]} \\ \mu_{\text{air}} \text{ at } 16.75 \text{ }^\circ\text{C} &= 1.8 \cdot 10^{-5} \text{ [kg/m}\cdot\text{s]} \\ k_{\text{air}} &= 0.0249 \text{ [W/m}\cdot\text{k]} \end{aligned}$$

For Equation [\ref{eq:beta2}](#) we calculate:

$$\begin{aligned} \beta &= \frac{\rho_{15} - \rho_{17.5}}{\rho_{17.5} (T_{17.5} - T_{15})} \\ \beta &= \frac{1.219 - 1.216}{1.216 \cdot (17.5 - 15)} = 9.9 \cdot 10^{-4} \text{ K}^{-1} \end{aligned}$$

We take the general formula for natural heat transfer Equation [\ref{eq:ght2}](#) in order to know h_i .

$$\begin{aligned} \frac{h_o \cdot L}{k_{\text{air}}} &= a \cdot \left(\frac{0.77^3 \cdot 1.219^2 \cdot 9.81 \cdot 9.9 \cdot 10^{-4} \cdot 10 \cdot (1.7 \cdot 10^{-5})^2}{1004.6 \cdot 1.7 \cdot 10^{-5} \cdot 0.0249} \right)^m \\ \frac{h_o \cdot L}{k_{\text{air}}} &= a \cdot (1.5 \cdot 10^8)^m \implies a = 0.59 \ ; \ m = \frac{1}{4} \\ \frac{h_o \cdot L}{k_{\text{air}}} &= 0.59 \cdot (1.5 \cdot 10^8)^{\frac{1}{4}} \\ \frac{h_o \cdot 0.77}{0.0255} &= 0.59 \cdot (1.5 \cdot 10^8)^{\frac{1}{4}} \\ h_o &= \frac{0.0255}{0.77} \cdot 0.59 \cdot (1.5 \cdot 10^8)^{\frac{1}{4}} \\ h_o &= 2.107 \ \frac{\text{W}}{\text{m}^2 \cdot \text{K}} \end{aligned}$$

We return to the Equation [\ref{eq:foruo}](#).

$$\begin{aligned} \frac{1}{U_0} &= \boxed{\frac{1}{h_i \cdot \frac{A_i}{A_o}}} + \frac{x}{k_{\text{PEHD}}} \cdot \frac{A_{\text{Lm}}}{A_o} + \boxed{\frac{1}{h_o}} \end{aligned}$$

$$\begin{aligned} A_i &= 3.424 \text{ m}^2 \\ A_o &= 3.456 \text{ m}^2 \\ k_{\text{PEHD}} \text{ thermal conductivity} &= 0.48 \text{ [kJ/(kg}\cdot\text{K)] } \text{ [The Engineering ToolBox, 2015].} \\ A_{\text{Lm}} &\text{ - log mean area} \\ A_{\text{Lm}} \text{ Equation } \ref{eq:alm} &\text{ is:} \end{aligned}$$

$$\begin{aligned} A_{\text{Lm}} &= \frac{A_o - A_i}{\ln\left(\frac{A_o}{A_i}\right)} \\ A_{\text{Lm}} &= \frac{0.55 - 0.545}{\ln\left(\frac{0.55}{0.545}\right)} \cdot 2 \cdot \pi = 3.44 \text{ m}^2 \end{aligned}$$

Now we know h_i , h_o and we can apply Equation [\ref{eq:uof}](#).

$$\begin{aligned} \frac{1}{U_0} &= \boxed{\frac{1}{438.648 \cdot \frac{3.424}{3.456}}} + \frac{0.005}{0.48 \cdot \frac{3.44}{3.456}} + \boxed{\frac{1}{2.107 \cdot 3.456}} \\ \frac{1}{U_0} &= 0.002 + 0.010 + 0.475 \\ U_0 &= 2.053 \frac{W}{m^2 \cdot K} \end{aligned} \quad \text{\label{eq:uof}}$$

From the heat transfer Equation \ref{eq:qwall} we can determine q_{wall} :

$$\begin{aligned} \dot{q}_{\text{wall}} &= U_0 \cdot A_0 \cdot \Delta T_{\text{Total}} \\ \dot{q}_{\text{wall}} &= 2.053 \cdot 3.456 \cdot 10 \\ \dot{q}_{\text{wall}} &= 70.952 \text{ W} \end{aligned} \quad \text{\label{eq:qwall}}$$

Until now we know the lost heat through the wall in W. The next calculations are for heat loss of water directly with air (top side water tank) as shown in Figure 18.

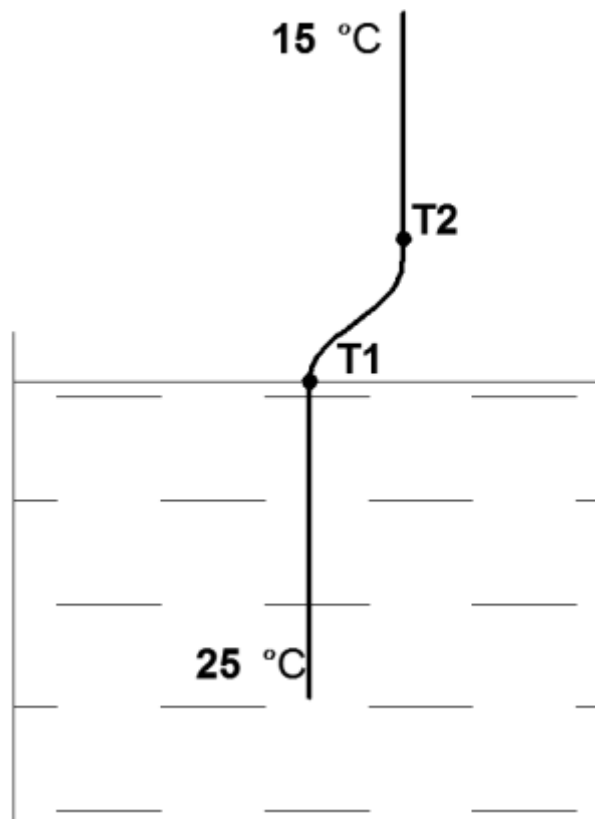

Figure 18: Heat flow between water and air

For water surface in direct contact with the air.

$$D = 1.1 \text{ m} \quad L = 0.9 \cdot D = 0.99$$

$$\rho_{\text{air}} \text{ at } 20 \text{ °C} = 1.205 \text{ [kg/m}^3\text{]}$$

$$\Delta T = 25 - 15 = 10 \text{ [°C]}$$

$$c_{p, \text{air}} \text{ at } 20 \text{ °C} = 1004.7 \text{ [J/kg}\cdot\text{K]}$$

$$\mu_{\text{air}} \text{ at } 20 \text{ °C} = 1.8 \cdot 10^{-5} \text{ [kg/m}\cdot\text{s]}$$

$$k_{\text{air}} = 0.0257 \text{ [W/m}\cdot\text{K]}$$

For β Equation \ref{eq:beta3} we calculate:

$$\begin{aligned} \beta &= \frac{\rho_{25} - \rho_{15}}{\rho_{15} (T_{25} - T_{15})} \\ \beta &= \frac{1.183 - 1.227}{1.227 \cdot (25 - 15)} = 3.6 \cdot 10^{-3} \text{ K}^{-1} \end{aligned} \quad \text{\label{eq:beta3}}$$

We replace in Equation \ref{eq:hw} with the above data and results:

$$\begin{aligned} \frac{h_w \cdot L}{k_{air}} = & a \cdot \left(\frac{0.99^3}{1.205^2} \cdot 9.81 \cdot 3.6 \cdot 10^{-3} \cdot 10 \cdot (1.8 \cdot 10^{-5})^2 \right) \cdot \\ & \frac{1004.7 \cdot 1.8 \cdot 10^{-5}}{0.0257} \right)^m \quad \frac{h_o \cdot L}{k_{air}} = & \\ & a \cdot (1.1 \cdot 10^9)^m \implies a = 0.14 \quad ; \quad m = \frac{1}{4} \quad \frac{h_w \cdot L}{k_{air}} = & \\ & 0.14 \cdot (1.1 \cdot 10^9)^{\frac{1}{4}} \quad \frac{h_w \cdot 0.99}{0.0257} = & 0.14 \cdot \\ & (1.1 \cdot 10^9)^{\frac{1}{4}} \quad \implies h_w = & \frac{0.0257}{0.99} \cdot 0.14 \cdot (1.1 \cdot \\ & 10^9)^{\frac{1}{4}} \quad \implies h_w = & 3.730 \cdot \frac{W}{m^2 \cdot K} \quad \label{eq:hw} \end{aligned}$$

To know the heat loss in watts we need again to know the coefficient \$U_0\$. The Equation \ref{eq:uoev} is more simplified because in this case we do not have a material between water and air.

$$\begin{aligned} \frac{1}{U_0} = & \boxed{\frac{1}{h_w \cdot \frac{A_i}{A_o}}} \quad \frac{1}{U_0} = \boxed{\frac{1}{3.730 \cdot \frac{3.424}{3.456}}} \quad \implies \\ \frac{1}{U_0} = & 0.271 \quad \implies U_0 = 3.695 \cdot \frac{W}{m^2 \cdot K} \quad \label{eq:uoev} \end{aligned}$$

From the heat transfer Equation \ref{eq:qev}, we calculate lost heat through evaporation (\$q_{ev}\$)

$$\begin{aligned} \dot{q}_{ev} = & U_0 \cdot A_0 \cdot \Delta T_{Total} \quad \implies \\ \dot{q}_{ev} = & 3.695 \cdot 3.456 \cdot 10 \quad \implies \dot{q}_{ev} = 127.699 \text{ W} \quad \label{eq:qev} \end{aligned}$$

And we finish with Equation \ref{eq:fuckingfinal} that results our lost heat in watts per seconds.

$$\begin{aligned} \dot{q}_{total} = & \dot{q}_{wall} + \dot{q}_{ev} \quad \implies \\ \dot{q}_{total} = & 70.952 + 129.699 \quad \implies \dot{q}_{total} = 198.631 \text{ W} \quad \label{eq:fuckingfinal} \end{aligned}$$

After this calculation we found one value, this value is the result after we apply a scenario. For safety, we will buy one 300 W heater.

- Automatic fish feeder

Automatic fish feeder tells his story, it feeds the fish through an automation process. In Table 37 we compare our proposed products.

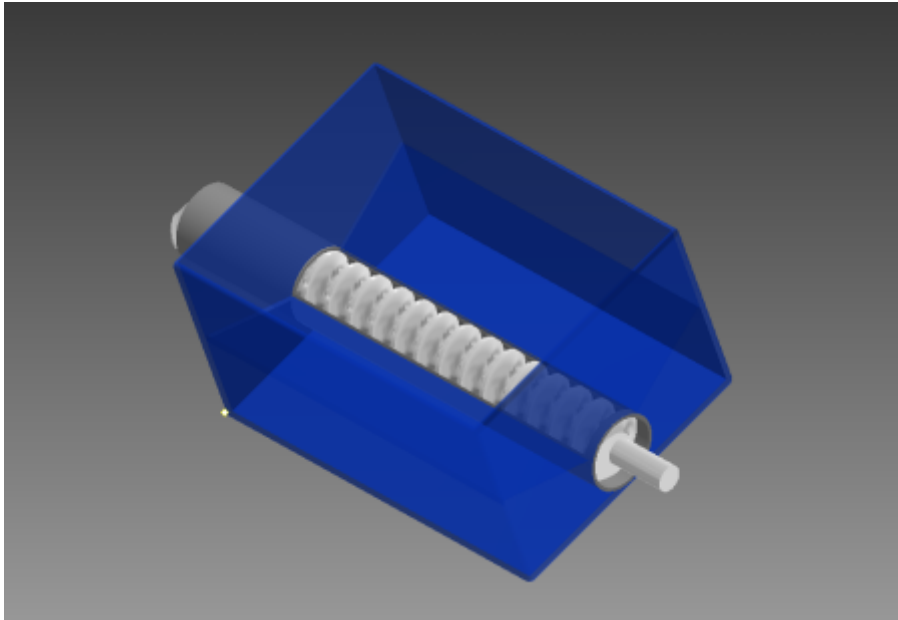

Figure 19: Designed Feeder

Our first idea was to create a feeder to feed the fish. The construction of the feeder was this: it was made from a Perspex-box, which had a spindle at the bottom. The food fell directly to the spindle because of the slope we had designed in the bottom of the box as seen in Figure 19. The screw was inside a PVC pipe open at the top. The spindle had a protrusion from the box so that the food fell into the tank, so now the pipe was open at the bottom. The operation was: we introduced the food at the top of the box, the food fell directly to the box. A motor turned the spindle until the food fell into the tank. This idea turned out to be too expensive to realise, so we decided to buy an existent feeder.

Table 37: Comparison table

Feeder	Daily Double II Automatic Fish Feeder	Unknown Fish Feeder
Price [€]	15.89	16.00

- Light LED

LED light is used to light the fish when the light is too poor or when it is totally dark. The light will be switched on only when you access the webcam remote view. In Table 38 we compare our proposed products.

Table 38: Comparison table

	Light LED 6 W 4200 K	Light LED 6 W 6400 K stainless square panel	12 W exterior	LED branco neutro 16 W
Consumption[W]	6	6	12	16
Price [€]	7.40	14.90	16.40	18.80

- Power supply

We need one power supply for Raspberry Pi with 12 V output and 1.5 A. In Table 39 we compare our proposed products.

Table 39: Comparison table

	Power Supply 12 V DC 1.5 A EU	Power Supply 12 V DC 2 A	Power Supply 12 V DC 2 A
Voltage [V]	12		
Current Intensity [A]	1.5	2.0	2.0

	Power Supply 12 V DC 1.5 A EU	Power Supply 12 V DC 2 A	Power Supply 12 V DC 2 A
Price [€]	12.24	15.93	7.50

- Switch board for routing power from wall

In the following Figure 20 and Figure 21 you can see the installed components, inside the provided PC power supply box and their adjustment at the aquaponics tank.

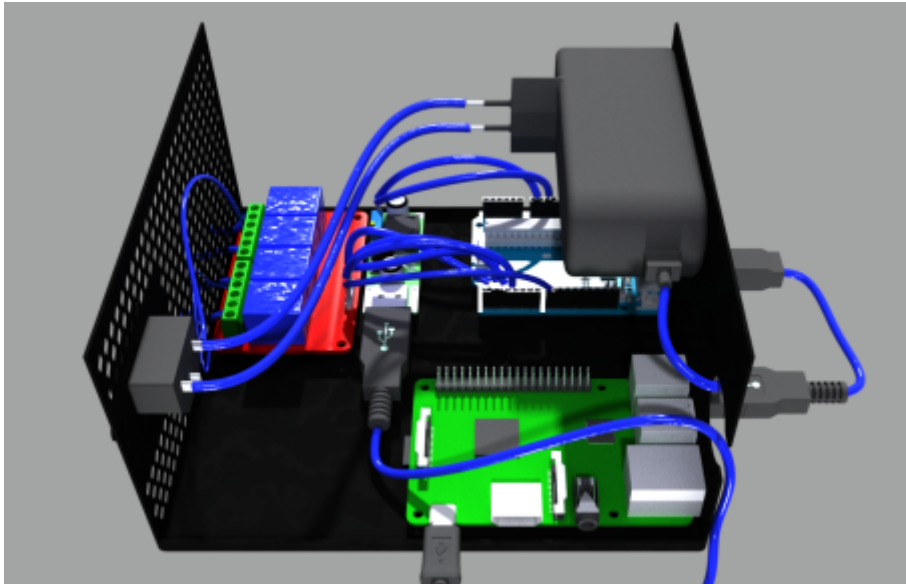

Figure 20: Installed Hardware Components

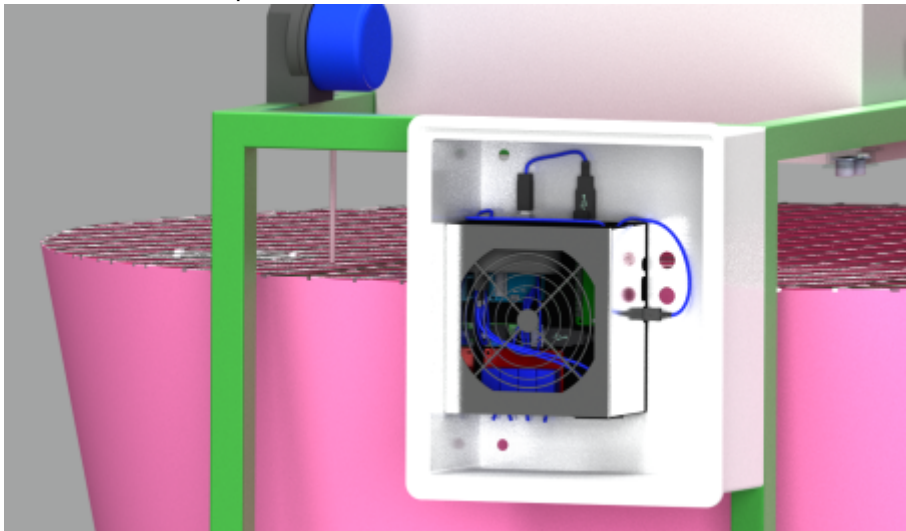

Figure 21: Installed Components Box

7.4 Design

7.4.1 Logo

In the brainstorm session for the name of the product we came up with names that are related to the aquaponic system and the controlling of it such as: Aquacontrollix, Simple Aquaponics and AquaM ('M' stands for monitoring).

In the end the decision was made that our product would have the name: Aquaponic Admin. Aquaponic is referring to the aquaponic system and Admin is referring to administrator. This product

name is chosen over the other ones by reason of it's very clear in what it has to represent and it has a flowing sound because both words start with the same letter.

The logo design process and the different approaches are displayed in Figure 22. The first idea for the logo was to create a fish which head and tail are connected through the Wi-Fi sign. This simple logo design had the focus on the monitoring of the fish. The second main idea was the use of outlines of a smartphone, tablet or laptop with a fish and a plant on the screen. In the variants is played with colours, outlines, a different fish and location of the elements.

The third idea was to use two hexagons who represent aquariums, each one contains a main element of the aquaponic system: a plant and a fish. One hexagon is overlaying the other one which refers to the fact that these two elements are working together. The variants are different in line thickness, font, colours and shapes.

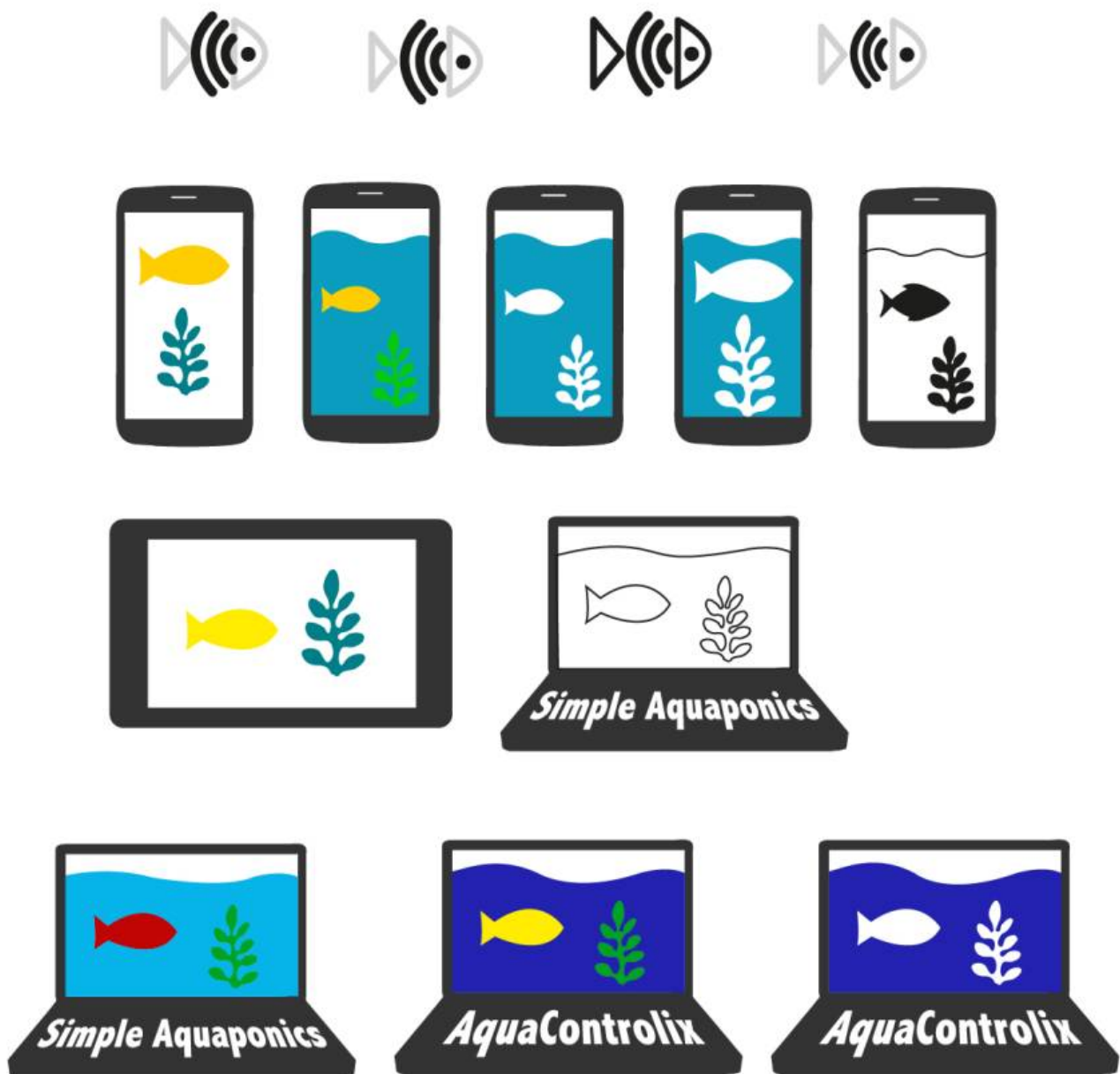

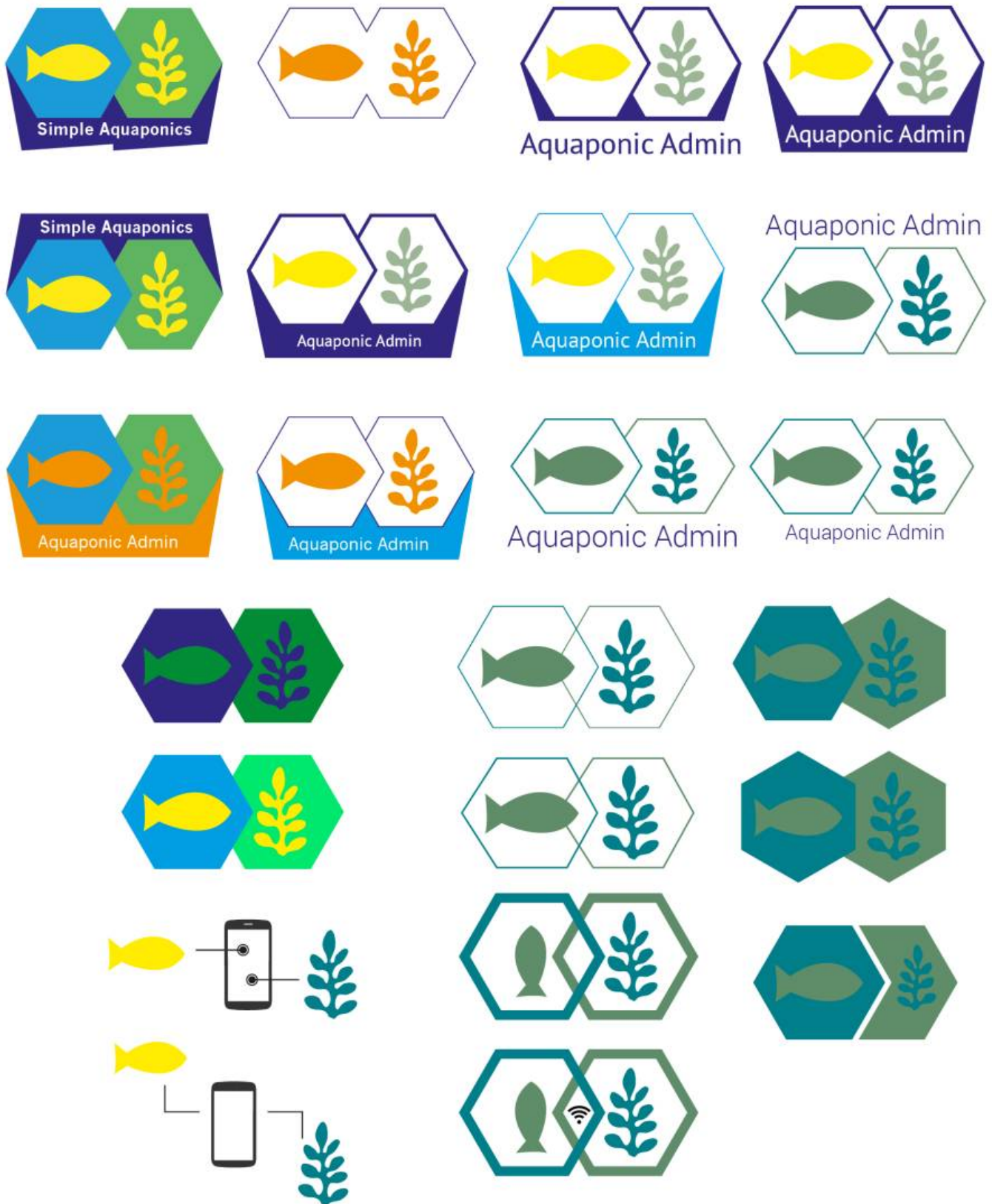

Figure 22: Logo development

The final logo as shown in Figure 23 contains a fish and plant who are connected with hexagons and the product name: Aquaponic Admin. The hexagons are representing aquariums and the overlapping of them is representing aquaponic culture which means plants and fish are living together. The fish and plants are having a simple but clear design.

Only to colours are used to avoid that the design would get bombastic. The blue colour has the colour code #26999E and is referring to the fish and the water. The green colour with the colour code #77AD82 is referring to the plants of the hydroponic part of the system.

The used font is PT Sans in bold, it is sans serif which means there are no small lines at the ends of characters. PT Sans has an open font license which means it can be redistributed without charge.



Figure 23: Final logo

7.4.2 Leaflet

The leaflet as shown in Figure 24 and 25 is has the format of an A4 and it is trifold. The font that is used in the leaflet is Dustismo, it is sans serif and free for commercial use. A sans serif font fits the best with the Aquaponic Admin logo font which is also in sans serif. The colours of the logo are used in the leaflet as triangles, the other triangles are in the component colours. The hexagons in the leaflet are standing for the different components of the aquaponic system.



Figure 24: Front side leaflet



Figure 25: Back side leaflet

7.4.3 Website

The user of our product can control the aquaponic system through a website as shown in Figure 26. This will be the welcome page. The background of the web app has a colour gradient that starts with the colour blue, colour code #6890a0 on top and goes down to a green colour with colour code #1a642f. The used font family is Helvetica Neue in a black colour. Helvetica is chosen because the letterforms have basic shapes which is ideal for the use on websites because it's very readable. The designer opinion says that Helvetica is both a classic and modern font and that makes it timeless. Every web page will contain the Aquaponic Admin logo and a footer with the initials of all the team members.

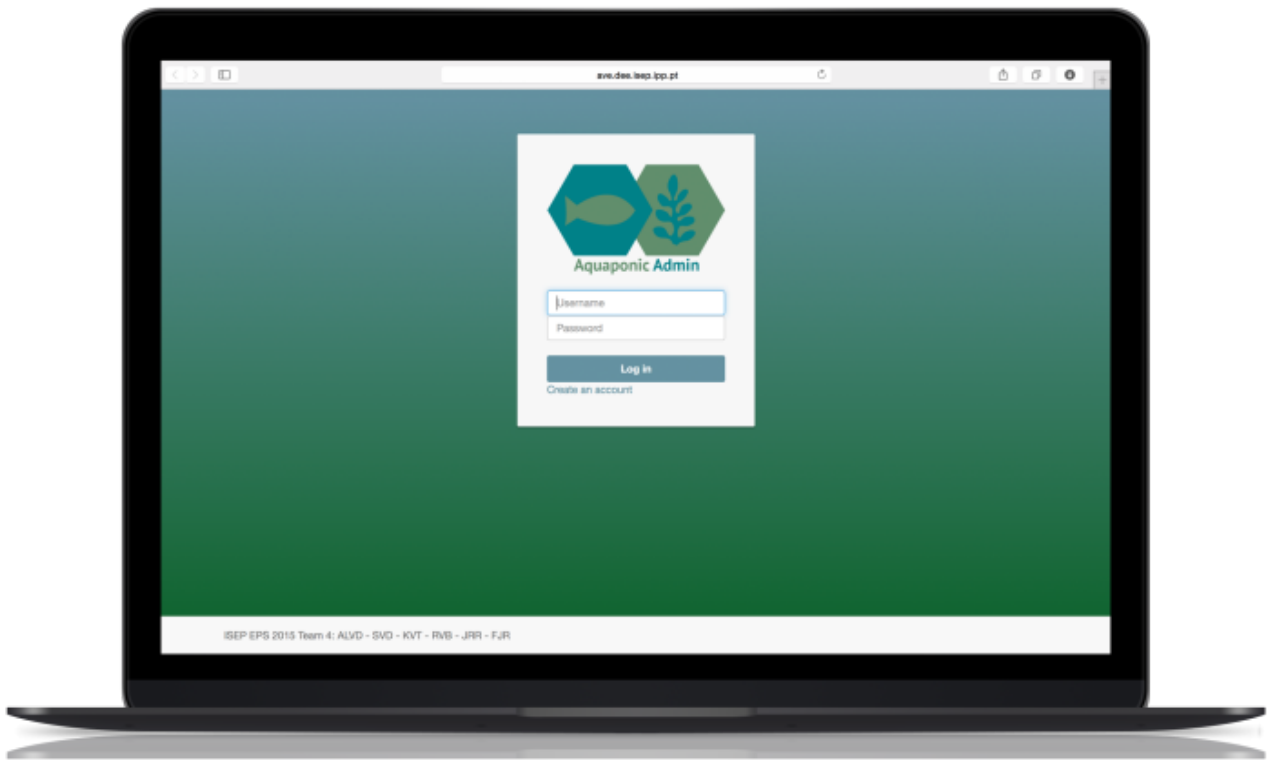

Figure 26: Website

7.4.4 Components

The original automatic feeder didn't fulfil the demanded requirements for the client. The purchased device at its original stage could not be connected and controlled via internet. For this purpose we redesigned the feeder. A stepper motor was bought for the modified version in order to control the food dispensation.

A plate was required so that the stepper could properly be installed in a fixed position. This is illustrated in the 3D drawing of Figure 27.

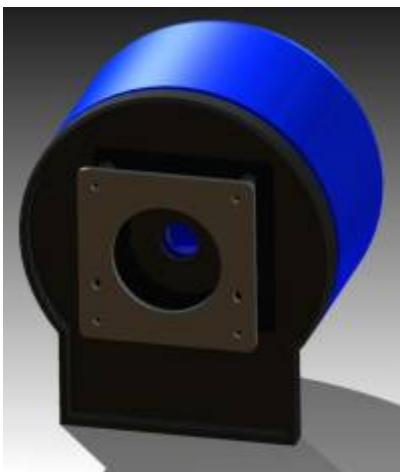

Figure 27: Plate support

The final design with the integrated circuit providing the stepper motor is displayed in Figure 28.

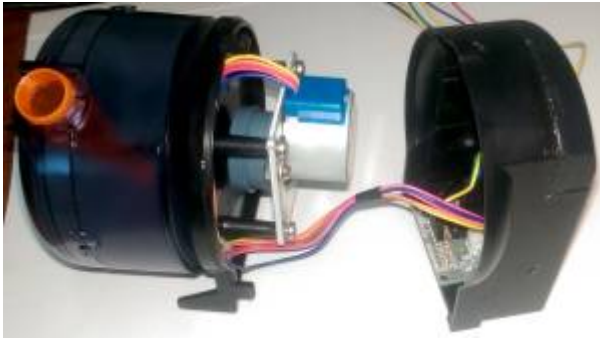

Figure 28: Modified feeder

A waterproof case was designed and built for the camera, so it would be possible to stream the fish's activities under water. Perspex was used as the major component to construct this case as it is illustrated in Figure 29. Furthermore the support is visible around the perspex case.



Figure 29: Waterproof camera case

For the ultrasonic sensor, which measures the water level, it was necessary to create a case that could avoid water splash on the sensor's circuit. For this purpose it was chosen to use perspex again. This model is displayed in Figure 30.

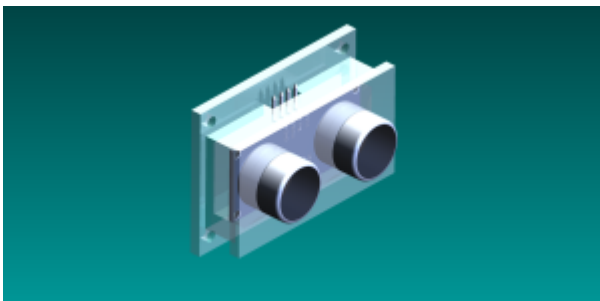

Figure 30: Ultrasonic sensor case

Initially it was planned to mount the heater vertically, for which a simple support was designed and built as it is shown in Figure 31.



Figure 31: Heater support

7.5 Functionalities

Our product has most of the expected functions of an aquaponics monitoring system. The original desired functionalities included a food dispenser, a camera as well as temperature and conductivity sensors. In the end the decision was remove the conductivity sensor. This loss came with the addition of two sensors one to measure water flow, one to measure water depth, and an LED light to help with visibility of the fish. In addition to these hardware functionalities there needed to be an Internet based method to view the information collected by the sensors. The full list of the tested functionalities are in the following section.

The main requirement for the product is to allow the user to monitor and control his aquaponic system using any device with internet access. The capabilities of the device can be generally divided into two groups – feeding the user with the information obtained from sensor and possibility to control the environment. The first is obtained by application of temperature sensor, ultrasound sensor used in order to check the level of water, infrared shooting sensor monitoring amount of food left in the feeder and flow sensor to ensure the pump is actually working with water. What is more the live video stream is available at any time in order to ensure the well-being of the fish. The other group makes it possible for user to control environmental conditions by manually turning the heater and pump on or off as well as feeding the fish remotely.

7.6 Tests and Results

In order to visualize the functionalities test and results Table 40 shows this information. Test column is simply to confirm the works as expected. The result column shows a status of pass, fail, or incomplete. A status of pass means the functionality performs as expected and needs no further development. A status fail means that in development and can be tested, but is not functioning as expected. This fail means that some further development is needed. A status in incomplete means that the function is in development and may need extensive work to earn a status of pass. For the tests and results concerning the feeder, light and heater it was necessary to hook up the devices with the Arduino in order to test the code. For the next step the challenge was to control the devices through the serial port from Raspberry Pi to Arduino. The final step was to control all three components from our website via Wi-Fi.

Table 40: Test and Results

Function	Test	Result
Access webpage	Confirmed	Passed
Register webpage		
Login webpage		
View checkstatus		
Page updates		
View change status page	Confirmed	Passed
Change page	Confirmed	Passed
Update database		
Video stream	Access on webpage	Failed
Unit powers on	Confirmed	Passed
Pi boots and runs application	Confirmed	Passed
Pi and Arduino Communicate	Confirmed	Passed

Function	Test	Result
Flow sensor	Arduino reads correct value from sensors	Passed
Temp sensor		
Heater		
Pump		
Light		
Depth sensor		
Feeder		

7.7 Conclusion

The development of the prototype was the most time and work-consuming stage. It actually started as soon as the research of the components to apply begun. As challenging as the whole assembly was, it is perceived as a success. We fulfilled main requirements concerning functionalities, application of the open-source solutions and energy efficiency of the product.

The main success was staying under the budget threshold while keeping the product fully functional and sustainable. We managed to find cheap solutions offering the same as products even four times as expensive.

The biggest problems during development were the heating of the board which we solved by mounting the box in a specific position, the current consumption which was solved by Arduino coding turning the sensors and stepper motor on only when requested by Raspberry Pi.

The other issue was to integrate Arduino code with Raspberry Pi controls and the web application. That problem took a lot of trials to solve but the ultimate solution was to make Raspberry Pi the master device responsible for writing to database and controlling the slave - Arduino.

The final prototype was mounted in a used PC power supply box. There were multiple modifications to be undergone in order to make all components fit in the right way. The installed final system is displayed in Figure 32. Inside the box are the following components:

- Raspberry Pi
- Converter from 12 V to 5 V
- Arduino Uno
- 4-channel Relay
- Power supply
- Principle switch button
- Power light converter from 240 V to 25 V



Figure 32: Final prototype

8. Conclusions

8.1 Discussion

The goal of our project was to develop a sustainable aquaponics monitoring system. At the completion of this report our product is far into the development stage, but incomplete. Though our team worked diligently and vigorously it was difficult to complete the task with delayed delivery of the needed components. Our prototype is consist of a functioning website, a Linux application that delivers information to the website, an Arduino sketch that reads information from previously discussed sensors, and a hardware module that runs the developed applications and operates the

sensors. Our team has all grown in regards to project management, and technical skills in our respective areas of study. The entire experience was focused on how we functioned as a team and overcame challenges both culturally and academically. Considering these categories our overall project was a success.

8.2 Future Development

Short-term there is little work needed to produce a fully functioning aquaponics monitoring system, but in long-term consideration there are several areas for improvements. The first short-term goal will be to insure we have functioning and quality components. Since we have an approved court model it will be simple to construct the prototype once this is completed. Secondly we will need to add error provisions to our application to prevent potential failures in the software. Finally we will need add additional security provisions to guarantee of Internet connect is not prone to disconnection and that our webcam is able to connect to the website without potential vulnerabilities. The long-term objectives are the same as the short term, but it is important to consider the improvised sustainability of a professional software developer reworking the website, and hardware – software interactions.

Bibliography

[**Osmobot, 2015**] <http://www.osmobot.com/aquaponics-monitor.html>

[**Smart Aquaponics Garden Controller, 2015**] http://www.kijanigrows.com/buy_now/

[**Sensaphone 400, 2015**] https://store.aquaponics.com/?route=product/product&product_id=77

[**Sensaphone 800, 2015**]

http://store.aquaponics.com/index.php?route=product/product&product_id=320

[**Open Aquarium, 2015**]

<http://www.cooking-hacks.com/blog/we-launch-open-aquarium-fish-tank-monitoring-and-aquaponics-platform-for-arduino>

[**Liming Guan Maryanne Mowen Don Hansen, 2009**] Liming Guan Maryanne Mowen Don Hansen, 2009. *Cost Management: Accounting and Control*. Mason, Ohio : South-Western, Chapter 2, ISBN 0324559674 9780324559675.

[**Wayne F. Cascio, 2015**] Wayne F. Cascio, 2015. *Psychology of Human Resource Management. International Encyclopedia of the Social & Behavioral Sciences*, 2, pp.348 – 352.

[**J. Rodney Turner Anne Keegan Martina Huemann, 2007**] J. Rodney Turner Anne Keegan Martina Huemann, April 2007. *Human resource management in the project-oriented company: A review. International Journal of Project Management*, 25, pp.315 – 323.

[**N. Grainger P. Marshall J. McKay, 2014**] N. Grainger P. Marshall J. McKay, 2014. *Rethinking Communication in IT Project Management. System Sciences (HICSS)*, pp.4315 - 4324.

[**J. A. Crispim L. H. Rodriguez-da-Silva, 2014**] J. A. Crispim L. H. Rodriguez-da-Silva, 2014. *The Project Risk Management Process, a Preliminary Study. Procedia Technology*, 16, pp.943 – 949.

[**J. Kelly A. Ledwith J.R. Turner, 2003**] J. Kelly A. Ledwith J.R. Turner, 2003. *Project management in small to medium-sized enterprises: A comparison between firms by size and industry. International Journal of Managing Projects in Business*, 2, pp.282 - 296.

[**P. Villanueva A. M. Echeverría Lazcano A. Pérez-Ezcurdia S. Marcelino-Sábada, 2014**] P. Villanueva A. M. Echeverría Lazcano A. Pérez-Ezcurdia S. Marcelino-Sábada, February 2014. *Project Risk Management Methodology for Small Firms. International Journal of Project Management*, 32, pp.137 - 144.

[**World Bank., 1996**] World Bank., 1996. *Procurement under IBRD loans and IDA credits : guidelines*.

Washington, D.C. : World Bank, Chapter 3, ISBN 082133218X 9780821332184.

[Aini Jaapar Mohamed Ali Berawi Hamzah Abdul Rahman Saipol Bari Abd Karim, 2007] Aini Jaapar Mohamed Ali Berawi Hamzah Abdul Rahman Saipol Bari Abd Karim, 2007. *A review on the issues and strategies of stakeholder management in the construction industry. Management in Construction and Researchers Association (MICRA)*, pp.1.

[Helga Willer, et al. Julisa Lernoud, 2015], [Helga Willer, et al. Julisa Lernoud, 2015], [Helga Willer, et al. Julisa Lernoud, 2015], [Helga Willer, et al. Julisa Lernoud, 2015], [Helga Willer, et al. Julisa Lernoud, 2015] Helga Willer, et al. Julisa Lernoud, 2015. *The World of Organic Agriculture. Statistics and Emerging Trends 2015*. Research Institute of Organic Agriculture (FiBL).

[John Thøgersen Athanasios Krystallis Polymeros Chrysochou Livia Marian, 2014], [John Thøgersen Athanasios Krystallis Polymeros Chrysochou Livia Marian, 2014] John Thøgersen Athanasios Krystallis Polymeros Chrysochou Livia Marian, October 2014. *The role of price as a product attribute in the organic food context: An exploration based on actual purchase data. Food Quality and Preference*, 37, pp.52 - 60.

[Karena J. Burke Kylie Dowd, 2013] Karena J. Burke Kylie Dowd, October 2013. *The influence of ethical values and food choice motivations on intentions to purchase sustainably sourced foods. Appetite*, 69, pp.137 - 144.

[Clemens Weiß, 2015] Clemens Weiß, 2015. *ECF Farm Berlin: Aquaponik-Farm in der Stadt*.

[Osmobot, 2015] Osmobot, 2015. *The World's First Aquaponics Monitor*.

[Open Aquarium, 2015] Open Aquarium, 2015. *Aquaponics and Fish Tank Monitoring for Arduino*.

[Sensaphone, 2015] Sensaphone, 2015. *Product Overview*.

[Jisc infoNet, 2015] Jisc infoNet, 2015. *Enhanced SWOT Analysis*.

[Richard E. Thompson Ken Semmens Laura Genello Elizabeth S. Hill Ximin Li Jillian P. Fry David C. Love, 2015] Richard E. Thompson Ken Semmens Laura Genello Elizabeth S. Hill Ximin Li Jillian P. Fry David C. Love, January 2015. *Commercial aquaponics production and profitability: Findings from an international survey. Aquaculture*, 435, pp.67 - 74.

[Business Dictionary, 2015] Business Dictionary, 2015. *Market Positioning*.

[Andreia Taveira da Gama, 2015] Andreia Taveira da Gama, 2015. *Marketing Script EPS: Identifying Competitive Advantages*.

[H. Krohmer Ch. Homburg, 2009], [H. Krohmer Ch. Homburg, 2009] H. Krohmer Ch. Homburg, 2009. *Grundlagen des Marketingsmanagements: Einführung in Strategie, Instrumente, Umsetzung und Unternehmensführung, 2. Auflage*. Gabler, ISBN 3834914975.

[Business Dictionary, 2015] Business Dictionary, 2015. *Pricing*.

[Voet van Wanderschoot, 1992] Voet van Wanderschoot, 1992. *Journal of Marketing*. pp.90.

[H. Krohmer Ch. Homburg, 2009] H. Krohmer Ch. Homburg, 2009. *Marketingmanagement: Strategie - Instrumente - Umsetzung - Unternehmensführung, 3. Auflage*. Gabler, ISBN 3834916560.

[H. Krohmer Ch. Homburg, 2009] H. Krohmer Ch. Homburg, 2009. *Marketingmanagement: Strategie - Instrumente - Umsetzung - Unternehmensführung, 3. Auflage*. Gabler, pp.904, ISBN 3834916560.

[E. Danneels, 2002] E. Danneels, September 2002. *The dynamics of product innovation and firm competences. Strategic Management Journal*, 23, pp.1095 - 1121.

[Van der Stede Merchant, 2007] Van der Stede Merchant, 2007. *Management Control Systems: Performance Measurement, Evaluation and Incentives, 2nd edition*. Prentice Hall, ISBN 0273708015.

[I.M. Crawford, 1997] I.M. Crawford, 1997. *Agricultural and food marketing management*. Food and Agriculture Organization of the United Nations, ISBN 9251039046 9789251039045.

[R.F. Hartley, 1979] R.F. Hartley, 1979. *Sales Management*.

[Mary Coulter Stephen P. Robbins, 2010] Mary Coulter Stephen P. Robbins, 2010. *Management, 11th Edition*. Prentice Hall, Chapter 18, ISBN 0-13-216384-5.

[salud y seguridad Guías sobre medio ambiente, 2007] salud y seguridad Guías sobre medio ambiente, February 2007. *Guías sobre medio ambiente, salud y seguridad para la fabricación de*

semiconductores y otros componentes electrónicos. pp.1.

[Álvaro Rojas, 2014] Álvaro Rojas, 2014. *Las vacas que “comían” teles y smartphones*. *Revista de Negocios del IEEM*, pp.87.

[María Azucena Vicente Molinaa Unai Tamayo Orbegoza, Julen Izaguirre Olaizola, 2012]

María Azucena Vicente Molinaa Unai Tamayo Orbegoza, Julen Izaguirre Olaizola, February 2012.

Firms' waste management in the company: Motivations for their implementation and associated improvements. *Investigaciones Europeas de Dirección y Economía de la Empresa*, 18, pp.216-227.

[Pia Tanskanen, 2013] Pia Tanskanen, February 2013. *Management and recycling of electronic waste*. *Acta Materialia*, 61(3), ELSEVIER, pp.1001-1011, ISSN 0018-9448.

[Yesid Ramos Y. Ulianov Hugo Andres Macias, 2012] Yesid Ramos Y. Ulianov Hugo Andres Macias, February 2012. *Illumination Benefits using LED high brightness bulb compare to traditional illumination systems*. *Alternative Energies and Energy Quality*, 18, IEEE, pp.216-227, ISBN 978-1-4673-4653-5.

[Roberto Bermejo, 2005] Roberto Bermejo, 2005. *La gran transición hacia la sostenibilidad*. *Principios y estrategias de economía sostenible*. CATARATA, ISBN 84-8319-224-1.

[Greenpeace, 2012] Greenpeace, 2012. *Guide Greener Electronics*.

[Expo Milano 2015 Belgium, 2015] <http://www.expo2015.org/en/participants/countries/belgium>

[M. C. King V. Dujon J. Dillard, 2008] M. C. King V. Dujon J. Dillard, 2008. *Understanding the Social Dimension of Sustainability*. Routledge, ISBN 0415964652.

[Mariana Villanueva Bringas, Juan Gaytán Iniestra, Marco García Vargas Pilar arroyo López, 2012]

Mariana Villanueva Bringas, Juan Gaytán Iniestra, Marco García Vargas Pilar arroyo López, September 2012.

Simulation of the recycling rate of electronic products. A system dynamics model for a reverse logistics network. *Contaduría y Administración*.

[ordem dos Engenheiros, 2013] ordem dos Engenheiros, 2013. *Código Deontológico*.

[Carlos Carapeto, Fátima Fonseca, 2012] Carlos Carapeto, Fátima Fonseca, September 2012.

Ética and Deontología - Manual de Formação. Ordem Dos Engenheiros Técnicos (OET), pp.20.

[unknown, 2012] <http://www.members.tripod.com/aromaticas/Calidad.html>

[C. Park, 2003] C. Park, 2003. *Plagiarism by university students - literature and lessons learned*.

Assessment & Evaluation in Higher Education, 28, pp.471-488.

[Alex Fernandez Muerza, 2012] Alex Fernandez Muerza, 2012. *Reciclar aparatos eléctricos y electrónicos, por qué y cómo hacerlo*. *Eroski Consumer*.

[Aquaponic Admin, 2015] <http://www.ave.dee.isep.ipp.pt/~Aquaponics/>

[eLinux, 2015] eLinux, 2015. *RPi USB Webcams*.

[Christie J. Geankoplis, 1993], [Christie J. Geankoplis, 1993] Christie J. Geankoplis, 1993.

Transport Processes and Unit Operations. Prentice-Hall International, Inc, Chapter 4, ISBN 0-13-045253-x.

[Christie J. Geankoplis, 1993] Christie J. Geankoplis, 1993. *Transport Processes and Unit Operations*. Prentice-Hall International, Inc, pp.254, ISBN 0-13-045253-x.

[Christie J. Geankoplis, 1993], [Christie J. Geankoplis, 1993] Christie J. Geankoplis, 1993.

Transport Processes and Unit Operations. Prentice-Hall International, Inc, pp.255, ISBN 0-13-045253-x.

[Christie J. Geankoplis, 1993] Christie J. Geankoplis, 1993. *Transport Processes and Unit*

Operations. Prentice-Hall International, Inc, pp.253, ISBN 0-13-045253-x.

[The Engineering ToolBox, 2015]

http://www.engineeringtoolbox.com/water-thermal-properties-d_162.html

[The Engineering ToolBox, 2015] http://www.engineeringtoolbox.com/air-properties-d_156.html

[The Engineering ToolBox, 2015]

http://www.engineeringtoolbox.com/thermal-conductivity-d_429.html

From:

<https://www.eps2015-wiki4.dee.isep.ipp.pt/> - **The European Project Semester (EPS) at ISEP**

Permanent link:

<https://www.eps2015-wiki4.dee.isep.ipp.pt/doku.php?id=report>

Last update: **2015/06/23 12:06**

